



TEX302TFT

TECHNICAL ANNEX VOLUME2



R.V.R. Elettronica S.r.l.
Via del Fonditore 2 / 2c
40138 · Bologna · Italy
Phone: +39 051 6010506 · Fax: +39 051 6011104
e-mail: info@rvr.it · web: http://www.rvr.it

Member of CISQ Federation



CERTIFIED MANAGEMENT SYSTEM
ISO 9001



The RVR Logo, and others referenced RVR products and services are trademarks of RVR Elettronica in Italy, other countries or both. RVR © 1998 all rights reserved.
All other trademarks, trade names or logos used are property of their respective owners.

Manufactured by R.V.R. ELETTRONICA Italy



Appendix A Piani di montaggio, schemi elettrici, liste componenti / *Component layouts, schematics, bills of material*

Questa parte del manuale contiene i dettagli tecnici riguardanti la costruzione delle singole schede componenti il TEX302TFT. L'appendice è composta dalle seguenti sezioni:

This part of the manual contains the technical details about the different Cards of the TEX302TFT. This appendix is composed of the following sections:

Description	RVR Code	Vers.	Page
Wiring Diagrams	/	1.0	1
Main Board	SLMA0276R04V01	1.1	3
Stereo Coder Card	SLCTC30V03V01	1.1	8
Control Card	SLCNTMOS07.300	1.3	11
PA RF Power Supply	SLPS0468R01V02	1.0	14
Power Amplifier	SLRF0484R03V01	1.1	16
Panel Card	SLPC0463R05V01	1.0	19
Power Supply	KPSL5012R01A	1.0	24
Telemetry Card	SLTL0509R01V01	1.1	33
Clipper Card	SLCS0391R01V02	1.0	36
15kHz Audio Filter Card	SLAU0469R01V04	2.2	38

Document History

Date	Version	Reason	Code	Editor
04/03/2021	1.0	First Release	/	J.H. Berti
27/05/2022	1.1	Wiring Diagram, SLMA0276R04V01, SLCNTMOS07.300, SLRF0484R03V01 & SLPC0463R05V01 Upgrade	/	J.H. Berti

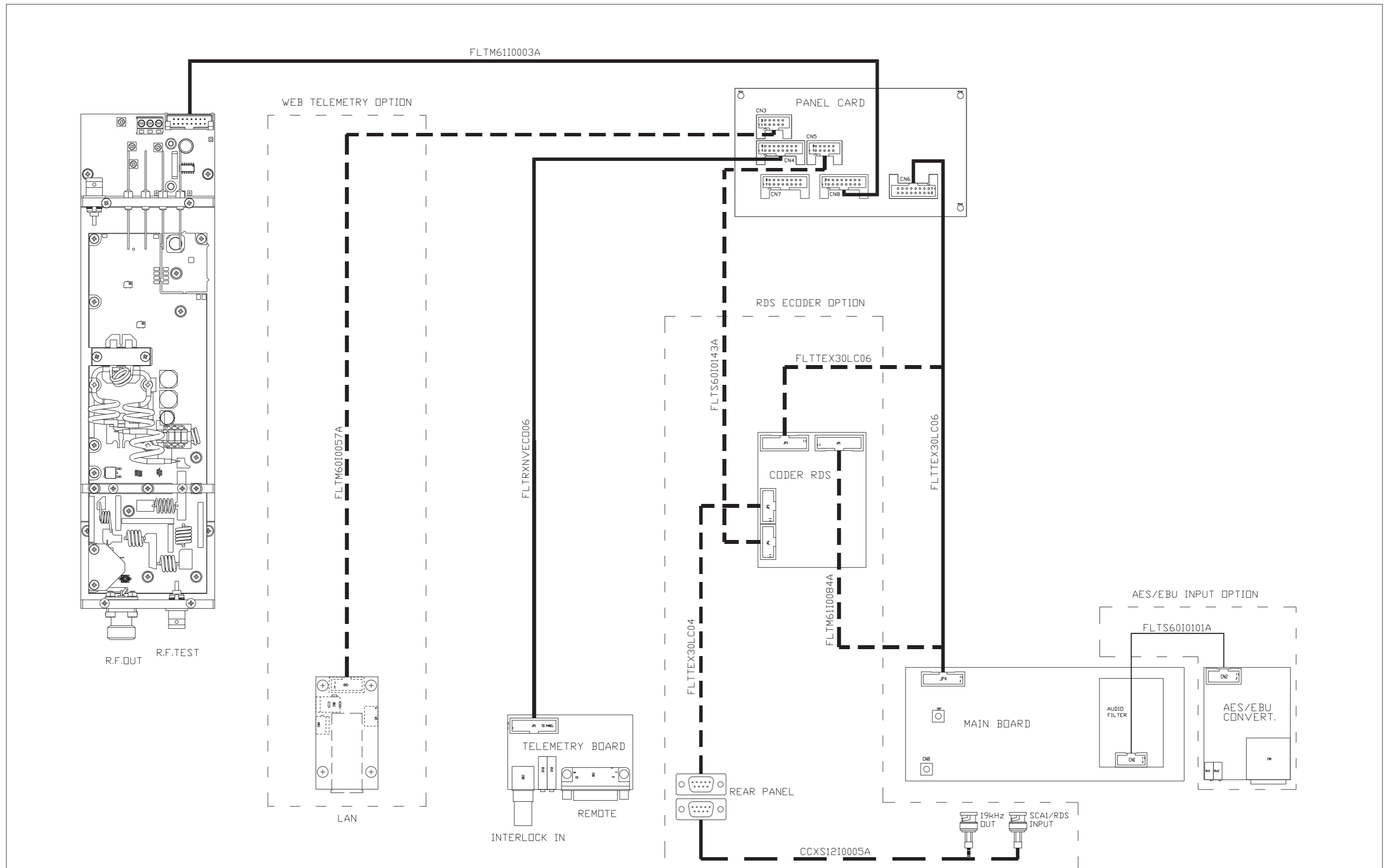

	PRODUCT NAME :	TEX302TFT	PART NAME :	WIRING DIAGRAM TEX302TFT	
	DESIGNER :	G. DE DONNO	DATE :	11-01-21	
ARCHIVING :	"RVRUT" SERVER, "RILASCIATI" FOLDER	PROJECT CODE :	045	DOCUMENT CODE :	/
		REVISION :	1.0	SCALE :	/
		SIZE :	A3	PAGE :	1 DI 2

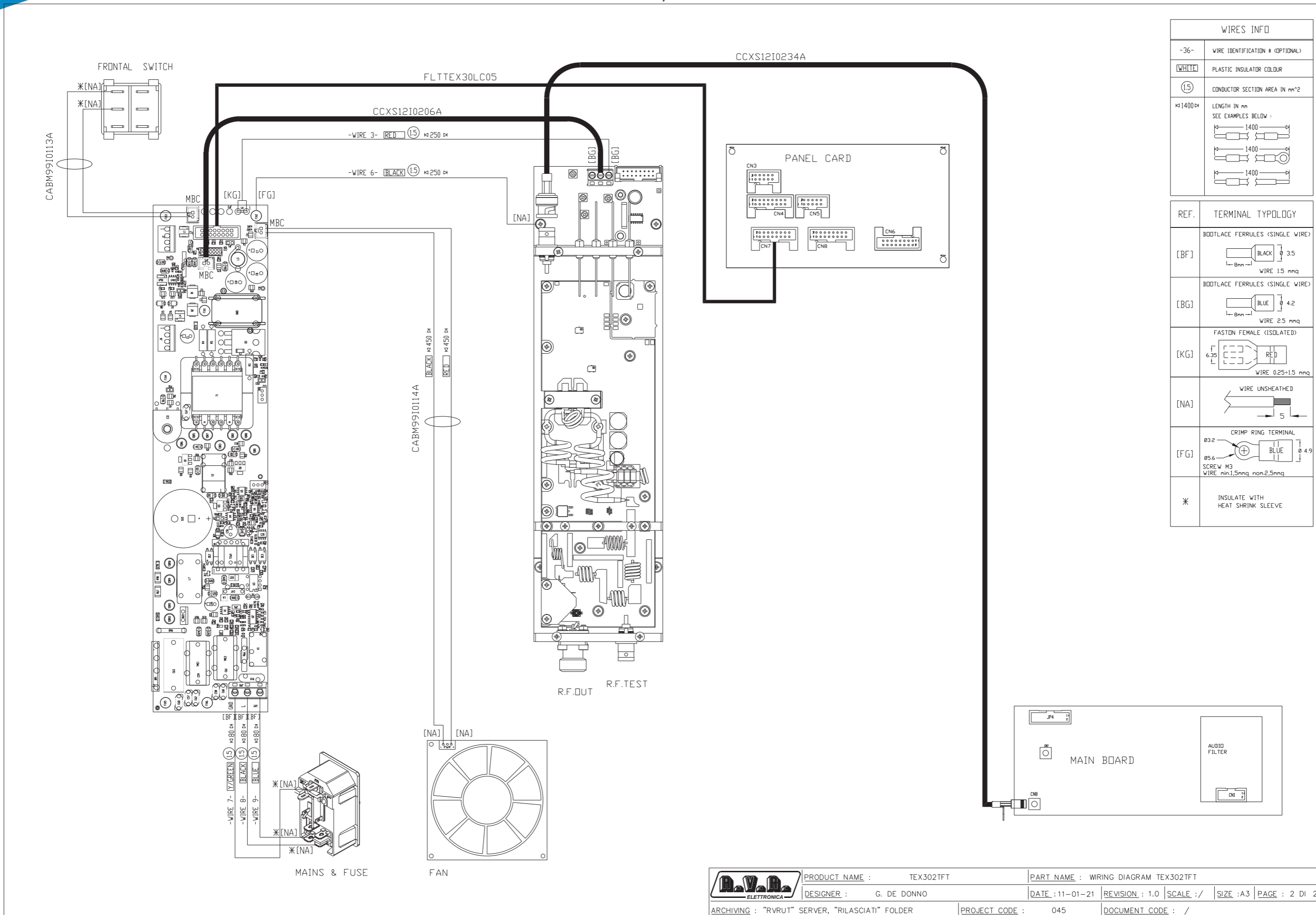

WIRES INFO	
-36-	WIRE IDENTIFICATION # (OPTIONAL)
[WHITE]	PLASTIC INSULATOR COLOUR
(1.5)	CONDUCTOR SECTION AREA IN mm ²
4x1400	LENGTH IN mm SEE EXAMPLES BELOW:
REF.	TERMINAL TYPOLOGY
[BF]	BOOTLACE FERRULES (SINGLE WIRE) WIRE 1.5 mmq
[BG]	BOOTLACE FERRULES (SINGLE WIRE) WIRE 2.5 mmq
[KG]	FASTON FEMALE (ISOLATED) WIRE 0.25+1.5 mmq
[NA]	WIRE UNSHEATHED
[FG]	CRIMP RING TERMINAL Ø3.2 Ø5.6 SCREW M3 WIRE min.1.5mmq max.2.5mmq
*	INSULATE WITH HEAT SHRINK SLEEVE

	PRODUCT NAME : TEX302TFT	PART NAME : WIRING DIAGRAM TEX302TFT
	DESIGNER : G. DE DONNO	DATE : 11-01-21 REVISION : 1.0 SCALE : / SIZE : A3 PAGE : 2 DI 2
ARCHIVING : "RVRUT" SERVER, "RILASCIATI" FOLDER		PROJECT CODE : 045 DOCUMENT CODE : /

SLMA0276R04V01

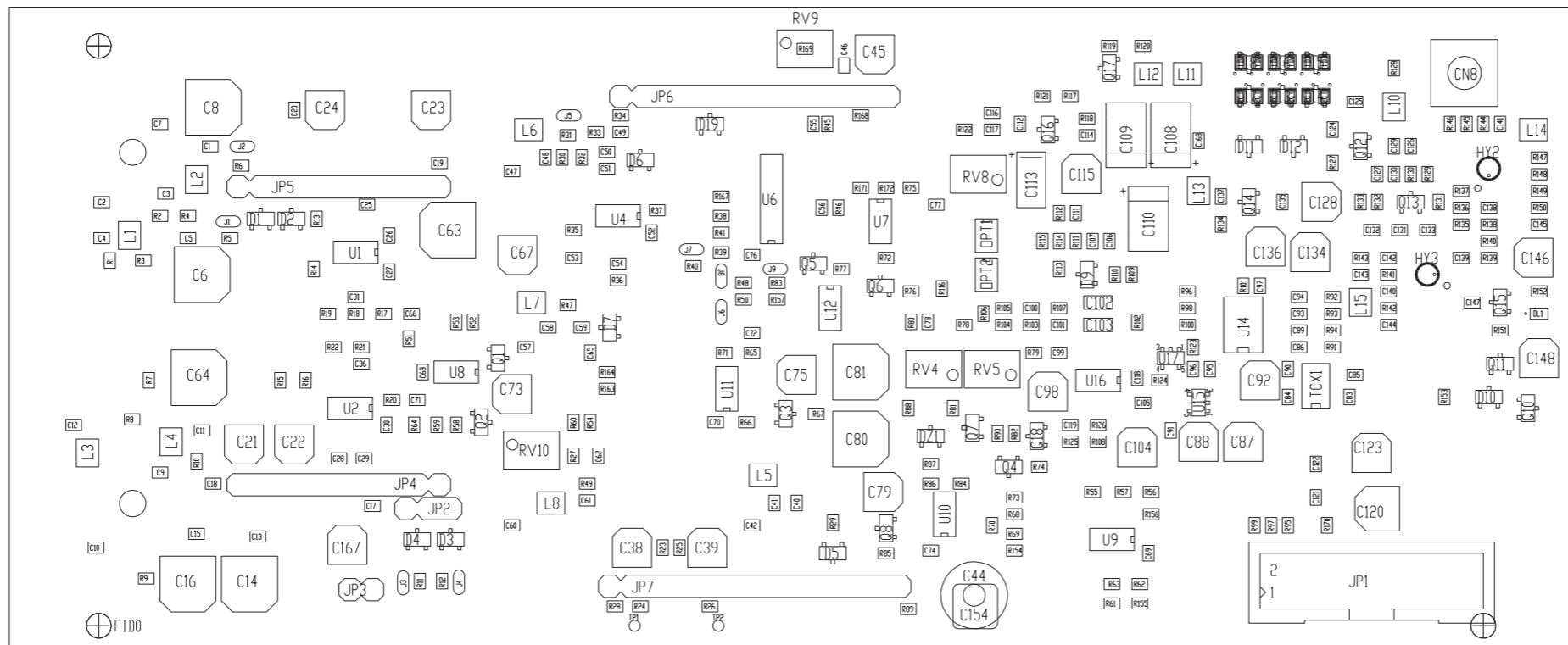
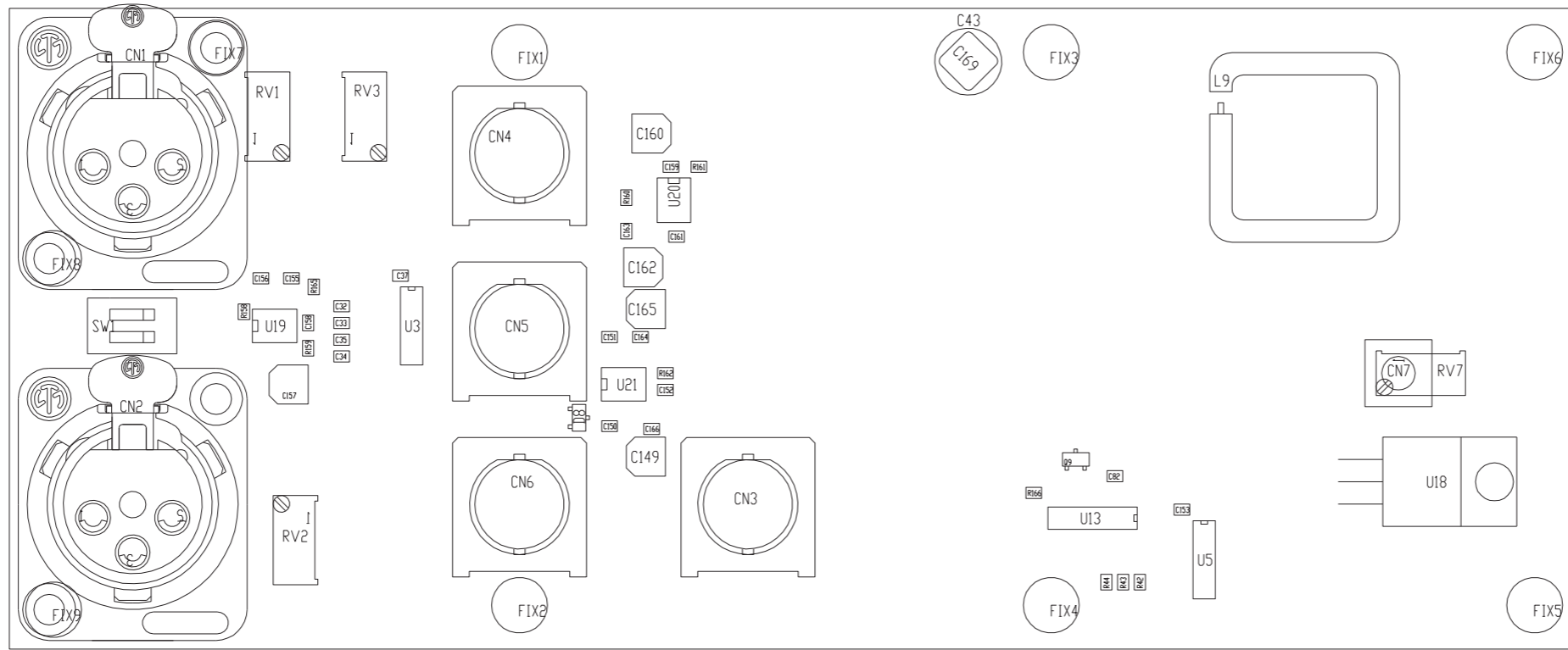

PART NAME : MAIN BOARD

DATE : 18/08/21 REVISION : 1.0 SCALE : 1:1 SIZE : A4 PAGE : 1 DI 1

PROJECT CODE : 252 DOCUMENT CODE : SLMA0276R04V**

PRODUCT NAME : TEX-TFT

DESIGNER : FRANCESCHI A.

ARCHIVING : "RVUT" SERVER, "RILASCIATI" FOLDER



SLMA0276R04V01

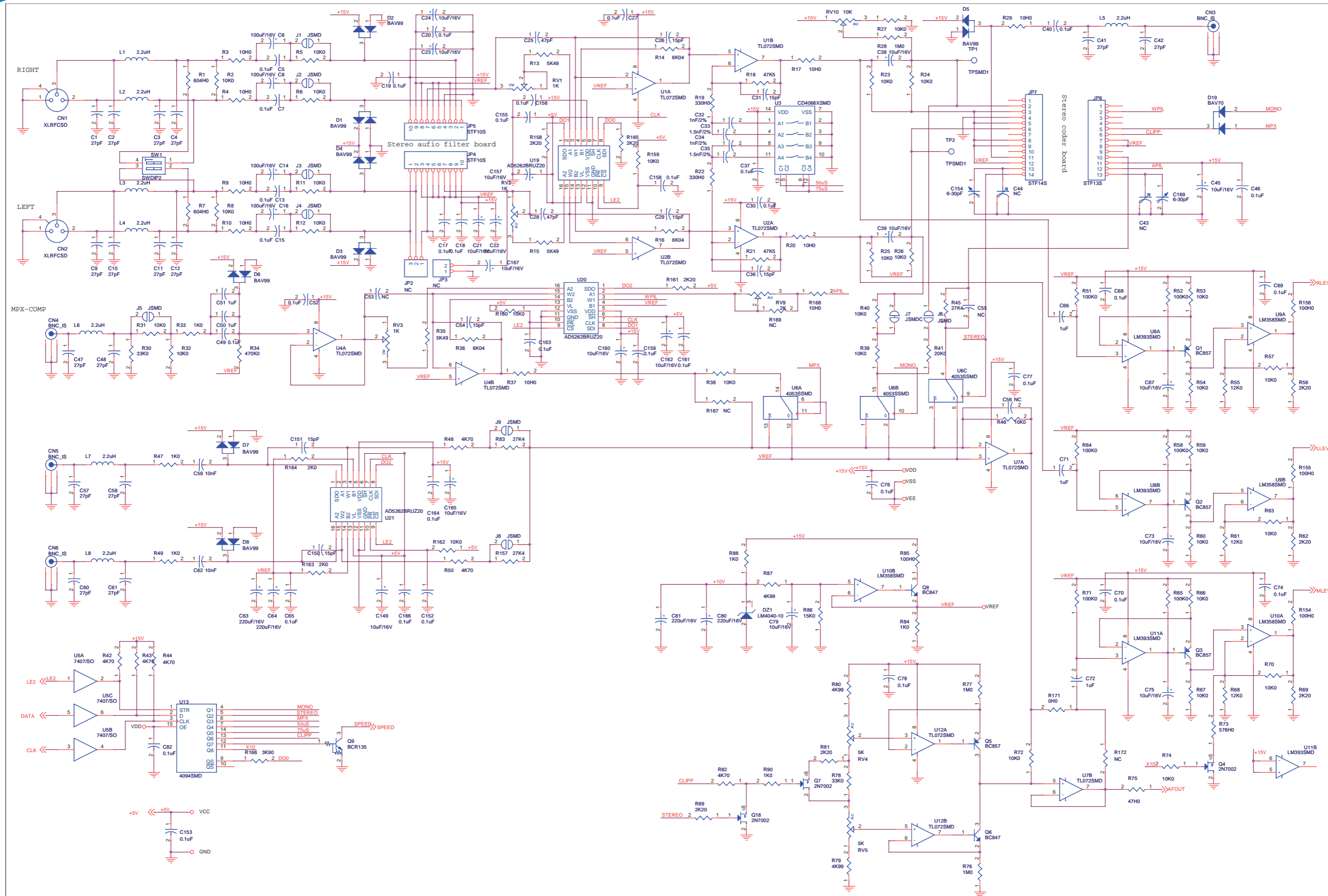

Description: TEX-TFT MAIN BOARD - AUDIO SECTION		
Designer: Franceschi A.	Size: A2	Page: 1 of 3
Part No.: SLMA0276R04V01	Rev. 1.1	Date: 02/02/2022



SLMA0276R04V01

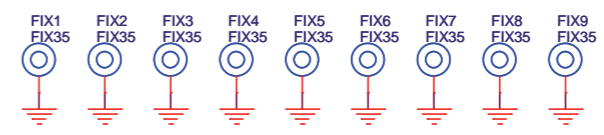
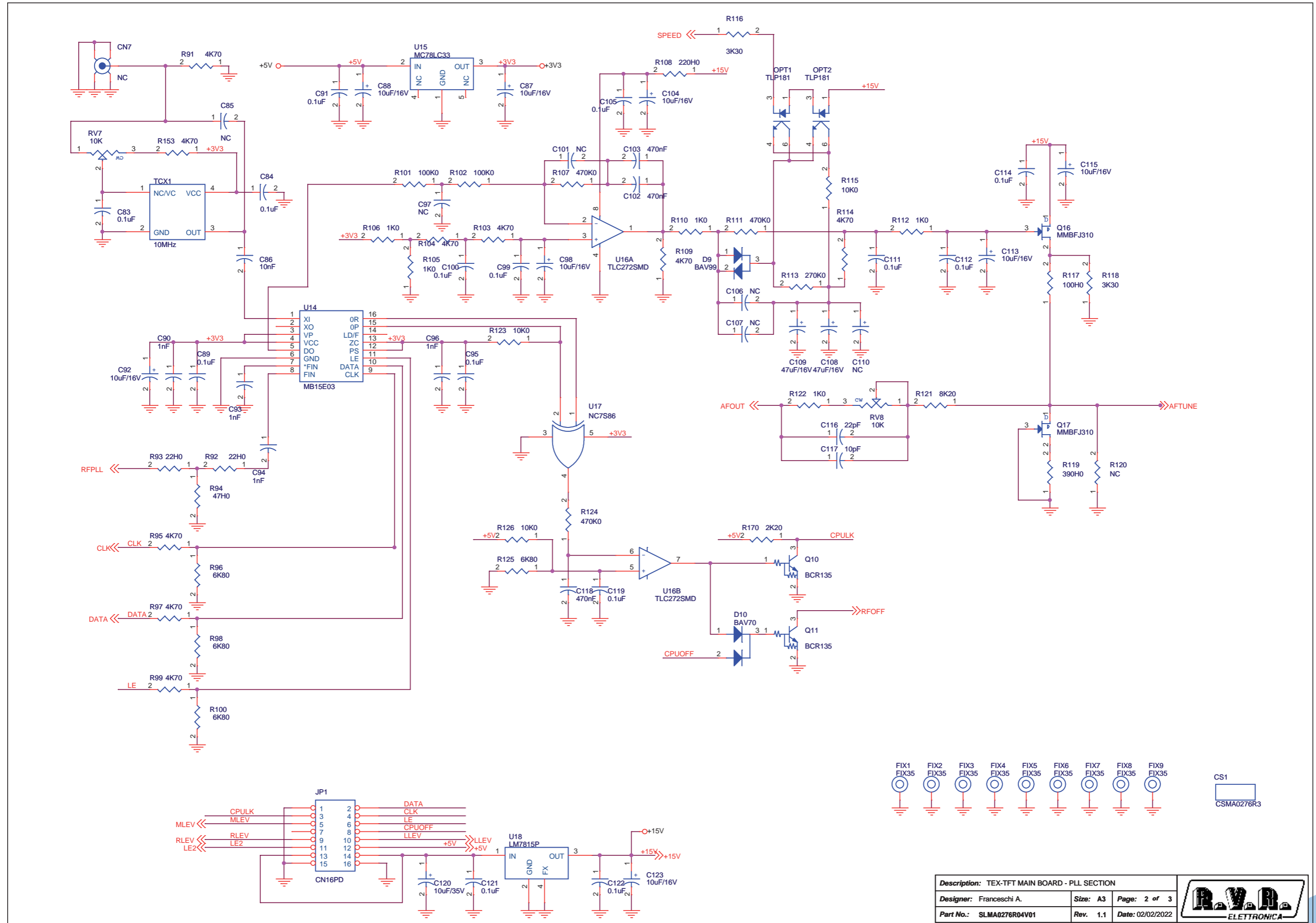

Description: TEX-TFT MAIN BOARD - PLL SECTION		
Designer: Franceschi A.	Size: A3	Page: 2 of 3
Part No.: SLMA0276R04V01	Rev: 1.1	Date: 02/02/2022



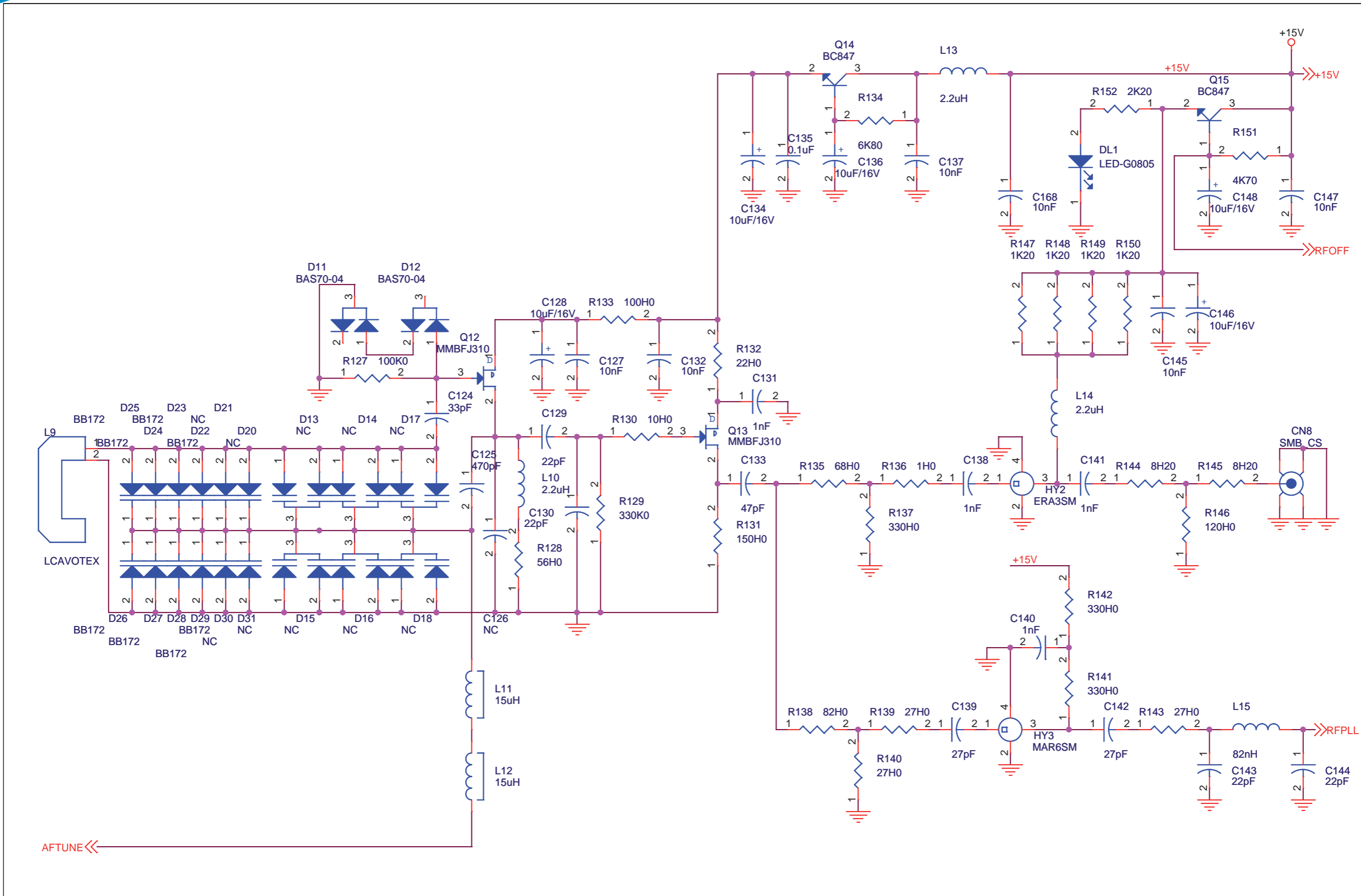

AFTUNE <<

Description: TEX-TFT MAIN BOARD - VCO DRV SECTION			
Designer: Franceschi A.	Size: A4	Page: 3 of 3	
Part No.: SLMA0276R04V01	Rev.: 1.1	Date: 02/02/2022	

SLMA0276R04V01

TEX-TFT MAIN BOARD Revised: 02/02/2022
 SLMA0276R04V01 Revision: 1.1
 Franceschi A.

Item	Quantity	Reference	Part	Description
1	2	CN1, CN2	XLRFCSD	XLR fem. PCB conn.
2	4	CN3, CN4, CN5, CN6	BNC_IS	Metal BNC conn.
3	1	CN7	NC	SMB pcb conn.
4	1	CN8	SMB_CS	SMB pcb conn.
5	1	CS1	CSMA0276R3	Printed Circuit board
6	18	C1, C2, C3, C4, C9, C10, C11, C12, C41, C42, C47, C48, C57, C58, C60, C61, C139, C142	27pF	0805 SMD capacitor
7	49	C5, C7, C13, C15, C17, C18, C19, C20, C27, C30, C37, C40, C46, C49, C52, C65, C68, C69, 0.1uF C70, C74, C76, C77, C78, C82, C83, C84, C89, C91, C95, C99, C100, C105, C111, C112, C114, C119, C121, C122, C135, C152, C153, C155, C156, C158, C159, C161, C163, C164, C166		0805 SMD capacitor
8	4	C6, C8, C14, C16	100uF/16V	SMD electr. cap. 6.3mm
9	29	C21, C22, C23, C24, C38, C39, C45, C67, C73, C75, C79, C87, C88, C92, C98, C104, C115, 10uF/16V C123, C128, C134, C136, C146, C148, C149, C157, C160, C162, C165, C167		SMD electr. cap. 4mm
10	3	C25, C28, C133	47pF	0805 SMD capacitor
11	7	C26, C29, C31, C36, C54, C150, C151	15pF	0805 SMD capacitor
12	2	C32, C34	1nF/2%	0805 COG SMD capacitor
13	2	C33, C35	1.5nF/2%	0805 COG SMD capacitor
14	2	C43, C44	NC	Ceramic comp. dia. 7mm
15	5	C50, C51, C66, C71, C72	1uF	0805 SMD capacitor
16	9	C53, C55, C56, C85, C97, C101, C106, C107, C126	NC	0805 SMD capacitor
17	9	C59, C62, C86, C127, C132, C137, C145, C147, C168	10nF	0805 SMD capacitor
18	4	C63, C64, C80, C81	220uF/16V	SMD electr. cap. 6.3mm
19	8	C90, C93, C94, C96, C131, C138, C140, C141	1nF	0805 SMD capacitor
20	2	C102, C103	470nF	1206 SMD capacitor
21	2	C108, C109	47uF/16V	SMD tantalium cap. size D
22	1	C110	NC	SMD tantalium cap. size D
23	1	C113	10uF/16V	SMD tantalium cap. size C
24	5	C116, C129, C130, C143, C144	22pF	0805 SMD capacitor
25	1	C117	10pF	0805 SMD capacitor
26	1	C118	470nF	0805 SMD capacitor
27	1	C120	10uF/35V	SMD electr. cap. 5mm
28	1	C124	33pF	0805 SMD capacitor
29	1	C125	470pF	0805 SMD capacitor
30	2	C154, C169	6-30pF	Var. comp. Murata TZB4A
31	1	DL1	LED-G0805	Green LED SMD 0805
32	1	DZ1	LM4040-10	SMD SOT23 precision Zener
33	9	D1, D2, D3, D4, D5, D6, D7, D8, D9	BAV99	Dual diode SMD SOT23
34	2	D10, D19	BAV70	Dual diode SMD SOT23
35	2	D11, D12	BAS70-04	Dual diode SMD SOT23
36	6	D13, D14, D15, D16, D17, D18	NC	Dual diode Varicap SMD SOT23
37	4	D20, D21, D30, D31	NC	Varicap diode SOD323
38	8	D22, D23, D24, D25, D26, D27, D28, D29	BB172	Varicap diode SOD323
39	9	FIX1, FIX2, FIX3, FIX4, FIX5, FIX6, FIX7, FIX8, FIX9	FIX35	3.5mm Fixing hole
40	1	HY2	ERA35M	Hybrid MAR/ERA
41	1	HY3	MAR65M	Hybrid MAR/ERA
42	1	JP1	CN16PD	16 way pcb conn. with holder
43	1	JP2	NC	Male strip 3 pin
44	1	JP3	NC	Male strip 2 pin
45	2	JP4, JP5	STF105	Female strip 10 pin
46	1	JP6	STF135	Female strip 13 pin
47	1	JP7	STF145	Female strip 14 pin
48	8	J1, J2, J3, J4, J5, J6, J8, J9	J5MD	2 pad SMD jumper
49	1	J7	J5MDC	2 pad SMD jumper closed
50	11	L1, L2, L3, L4, L5, L6, L7, L8, L10, L13, L14	2.2uH	SMD inductor 3225 (1210)
51	1	L9	LCAVOTEX	Inductor Cable for TEX
52	2	L11, L12	15uH	SMD inductor 3225 (1210) shielded
53	1	L15	82nH	SMD inductor 3225 (1210)
54	2	OPT1, OPT2	TLP181	Optocoupler SMD SO6
55	4	Q1, Q2, Q3, Q5	BC857	PNP trans. SOT23
56	3	Q4, Q7, Q18	2N7002	Trans. FET SOT23
57	4	Q6, Q8, Q14, Q15	BC847	NPN trans. SOT23
58	3	Q9, Q10, Q11	BCR135	Digital NPN trans. SOT23
59	4	Q12, Q13, Q16, Q17	MMBFJ310	Trans. FET SOT23
60	3	RV1, RV2, RV3	1K	Trimmer Rg V 3296W
61	2	RV4, RV5	5K	Trimmer Rg V 3269W SMD
62	1	RV7	10K	Trimmer Rg V 3296W
63	2	RV8, RV10	10K	Trimmer Rg V 3269W SMD
64	1	RV9	2K	Trimmer Rg V 3269W SMD

Item	Quantity	Reference	Part	Description
65	2	R1, R7	604H0	0805 SMD res.
66	34	R2, R5, R6, R8, R11, R12, R23, R24, R25, R26, R27, R31, R32, R38, R39, R40, R46, R53, R54, R57, R59, R60, R63, R66, R67, R70, R72, R74, R115, R123, R126, R159, R160, R162	10K0	0805 SMD res.
67	10	R3, R4, R9, R10, R17, R20, R29, R37, R130, R168	10H0	0805 SMD res.
68	3	R13, R15, R35	5K49	0805 SMD res.
69	3	R14, R16, R36	6K04	0805 SMD res.
70	2	R18, R21	47K5	0805 SMD res.
71	5	R19, R22, R137, R141, R142	330H0	0805 SMD res.
72	3	R28, R76, R77	1M0	0805 SMD res.
73	2	R30, R78	33K0	0805 SMD res.
74	11	R33, R47, R49, R84, R88, R90, R105, R106, R110, R112, R122	1K0	0805 SMD res.
75	4	R34, R107, R111, R124	470K0	0805 SMD res.
76	1	R41	20K0	0805 SMD res.
77	16	R42, R43, R44, R48, R50, R82, R91, R95, R97, R99, R103, R104, R109, R114, R151, R153	4K70	0805 SMD res.
78	3	R45, R83, R157	27K4	0805 SMD res.
79	9	R51, R52, R58, R64, R65, R71, R101, R102, R127	100K0	0805 SMD res.
80	3	R55, R61, R68	12K0	0805 SMD res.
81	10	R56, R62, R69, R81, R89, R152, R158, R161, R165, R170	2K20	0805 SMD res.
82	1	R73	576H0	0805 SMD res.
83	2	R75, R94	47H0	0805 SMD res.
84	3	R79, R80, R87	4K99	0805 SMD res.
85	6	R85, R117, R133, R154, R155, R156	100H0	0805 SMD res.
86	1	R86	15K0	0805 SMD res.
87	3	R92, R93, R132	22H0	0805 SMD res.
88	5	R96, R98, R100, R125, R134	6K80	0805 SMD res.
89	1	R108	220H0	0805 SMD res.
90	1	R113	270K0	0805 SMD res.
91	2	R116, R118	3K30	0805 SMD res.
92	1	R119	390H0	0805 SMD res.
93	4	R120, R167, R169, R172	NC	0805 SMD res.
94	1	R121	8K20	0805 SMD res.
95	1	R128	56H0	0805 SMD res.
96	1	R129	330K0	0805 SMD res.
97	1	R131	150H0	0805 SMD res.
98	1	R135	68H0	0805 SMD res.
99	1	R136	1H0	0805 SMD res.
100	1	R138	82H0	0805 SMD res.
101	3	R139, R140, R143	27H0	0805 SMD res.
102	2	R144, R145	8H20	0805 SMD res.
103	1	R146	120H0	0805 SMD res.
104	4	R147, R148, R149, R150	1K20	0805 SMD res.
105	2	R163, R164	2K0	0805 SMD res.
106	1	R166	3K90	0805 SMD res.
107	1	R171	0H0	0805 SMD res.
108	1	SW1	SWDIP2	2 ways switch slide dip
109	1	TCX1	10MHz	TCXO SMD 5x3.2mm
110	2	TP1, TP2	TPSMD1	Piazzola SMD d.1mm
111	5	U1, U2, U4, U7, U12	TL072SMD	Dual Op. SMD SO8
112	1	U3	CD4066XSMD	Analog Switch SMD SO14
113	1	U5	7407/SO	Hex buffer OC SMD SO14
114	1	U6	4053SSMD	Analog Switch SMD SO16
115	2	U8, U11	LM393SMD	Dual Comp. SMD SO8
116	2	U9, U10	LM358SMD	Dual Op. SMD SO8
117	1	U13	4094SMD	Shift Reg. SMD SO16
118	1	U14	MB15E03	Integrated PLL
119	1	U15	MC78LC33	Stab. SMD SOT23-5
120	1	U16	TLC272SMD	Dual Op. SMD SO8
121	1	U17	NC7586	XOR Port
122	1	U18	LM7815P	Voltage reg. TO220
123	3	U19, U20, U21	AD5262BRUZZ0	Dual 256 pos. dig. pot.

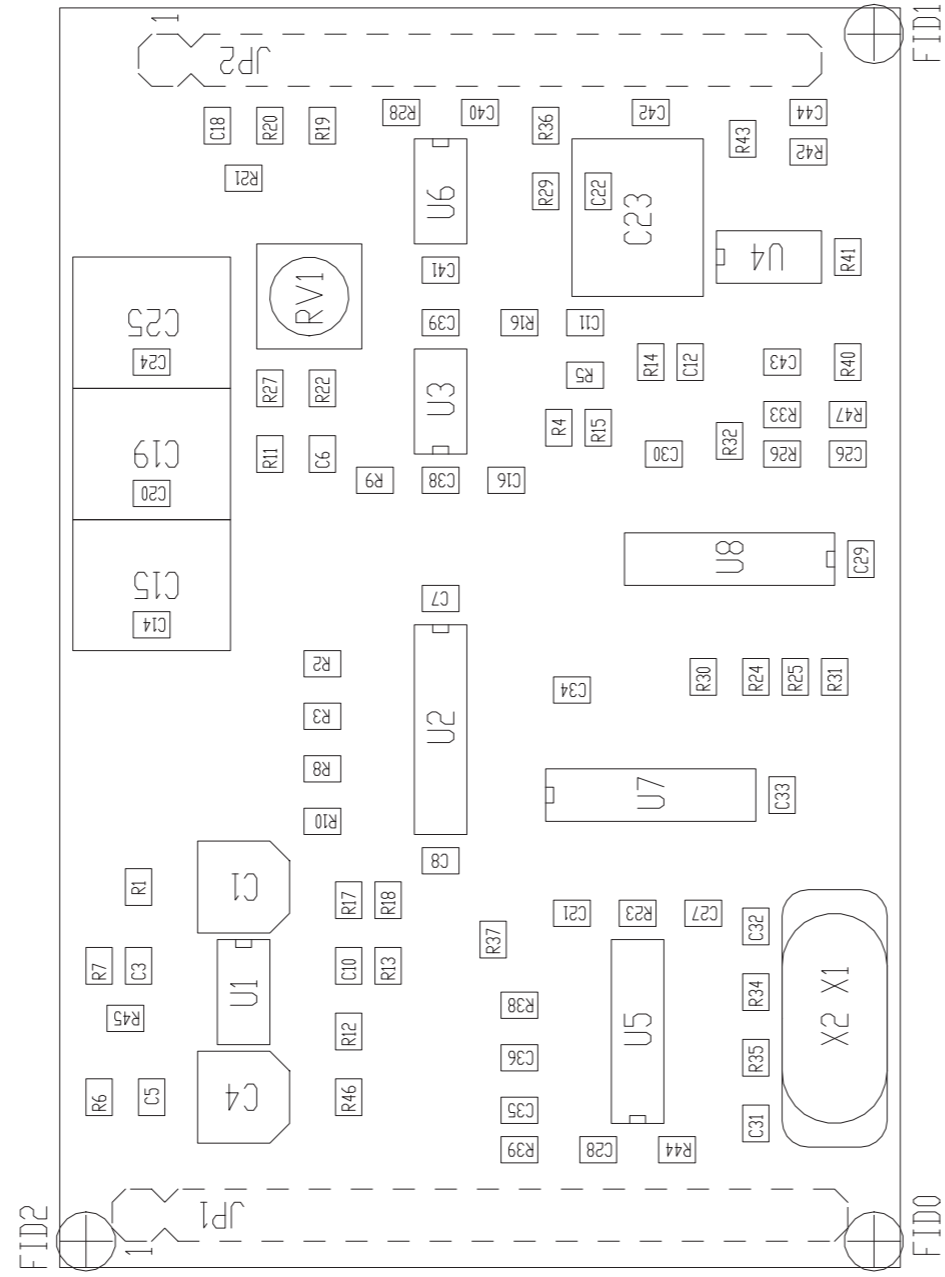

PRODUCT NAME : SERED CODER
 DESIGNER : FRANCESCHI A.
 ARCHIVING : "RVUT" SERVER, "RILASCIATI" FOLDER

PART NAME : CTC30 CODER CARD
 DATE : 26/01/15
 REVISION : 1.0
 PROJECT CODE : -

SCALE : 2:1
 SIZE : A4
 PAGE : 1 DI 1

DOCUMENT CODE : SLCTC30V03V**

SLCTC30V03V01

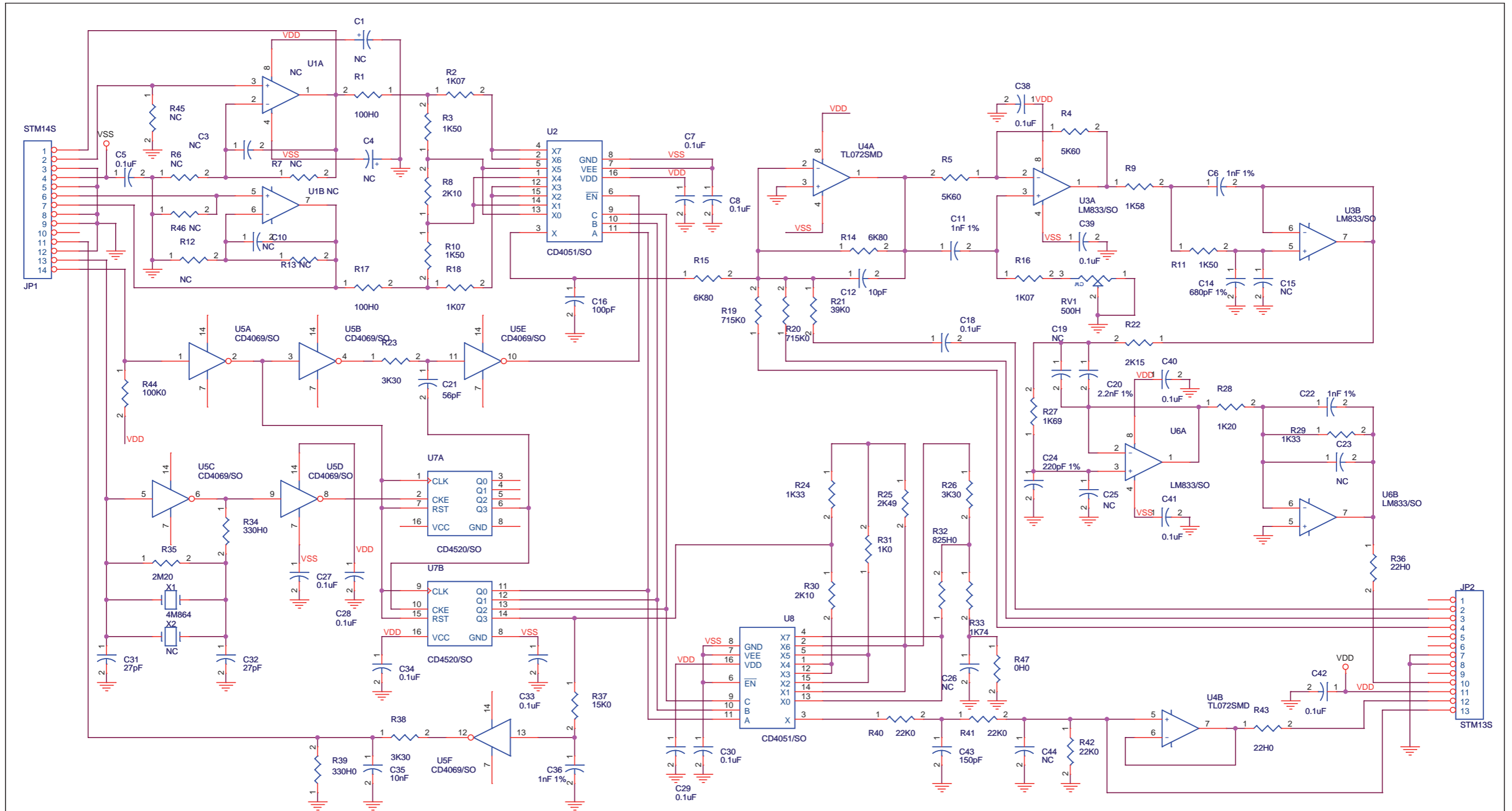

CS1
CSCTC30V03

Description: Coder Card		
Designer: Franceschi A.	Size: A3	Page: 1 of 1
Part No.: SLCTC30V03V01	Rev. 1.1	Date: 26/01/2015



SLCTC30V03V01

Coder Card Revised: 26/01/2015
 SLCTC30V03V01 Revision: 1.1
 Franceschi A.

Item	Quantity	Reference	Part	Description
1	1	C51	CSCTC30V03	Circuito stampato
2	2	C1,C4	NC	Cond. Elett. SMD d. 4mm
3	3	C3,C10,C26	NC	Cond. SMD 0805
4	15	C5,C7,C8,C18,C27,C28,C29, C30,C33,C34,C38,C39,C40, C41,C42	0.1uF	Cond. SMD 0805
5	4	C6,C11,C22,C36	1nF 1%	Cond. SMD 0805 COG
6	1	C12	10pF	Cond. SMD 0805
7	1	C14	680pF 1%	Cond. SMD 0805 COG
8	4	C15,C19,C23,C25	NC	Cond. Poliestere p 5mm (5*7mm)
9	1	C16	100pF	Cond. SMD 0805
10	1	C20	2.2nF 1%	Cond. SMD 0805 COG
11	1	C21	56pF	Cond. SMD 0805
12	1	C24	220pF 1%	Cond. SMD 0805 COG
13	2	C31,C32	27pF	Cond. SMD 0805
14	1	C35	10nF	Cond. SMD 0805
15	1	C43	150pF	Cond. SMD 0805
16	1	C44	NC	Cond. SMD 0805
17	1	JP1	STM14S	Strip maschio 14 pin
18	1	JP2	STM13S	Strip maschio 13 pin
19	1	RV1	500H	Trimmer SMD
20	2	R1,R17	100H0	Res. SMD 0805
21	3	R2,R16,R18	1K07	Res. SMD 0805
22	3	R3,R10,R11	1K50	Res. SMD 0805
23	2	R4,R5	5K60	Res. SMD 0805
24	6	R6,R7,R12,R13,R45,R46	NC	Res. SMD 0805
25	2	R8,R30	2K10	Res. SMD 0805
26	1	R9	1K58	Res. SMD 0805
27	2	R14,R15	6K80	Res. SMD 0805
28	2	R19,R20	715K0	Res. SMD 0805
29	1	R21	39K0	Res. SMD 0805
30	1	R22	2K15	Res. SMD 0805
31	3	R23,R26,R38	3K30	Res. SMD 0805
32	2	R24,R29	1K33	Res. SMD 0805
33	1	R25	2K49	Res. SMD 0805
34	1	R27	1K69	Res. SMD 0805
35	1	R28	1K20	Res. SMD 0805
36	1	R31	1K0	Res. SMD 0805
37	1	R32	825H0	Res. SMD 0805
38	1	R33	1K74	Res. SMD 0805
39	2	R34,R39	330H0	Res. SMD 0805
40	1	R35	2M20	Res. SMD 0805
41	2	R36,R43	22H0	Res. SMD 0805
42	1	R37	15K0	Res. SMD 0805

43	3	R40,R41,R42	22K0	Res. SMD 0805
44	1	R44	100K0	Res. SMD 0805
45	1	R47	OH0	Res. SMD 0805
46	1	U1	NC	Dual Op. SMD SO8
47	2	U2,U8	CD4051/SO	Analog Switch SMD SO16
48	2	U3,U6	LM833/SO	Dual Op. SMD SO8
49	1	U4	TL072SMD	Dual Op. SMD SO8
50	1	U5	CD4069/SO	Hex inverter SO14
51	1	U7	CD4520/SO	Dual binary counter
52	1	X1	4M864	Quarzo SMD HC495SMD
53	1	X2	NC	Quarzo HC18

SLCNTMOS07.300

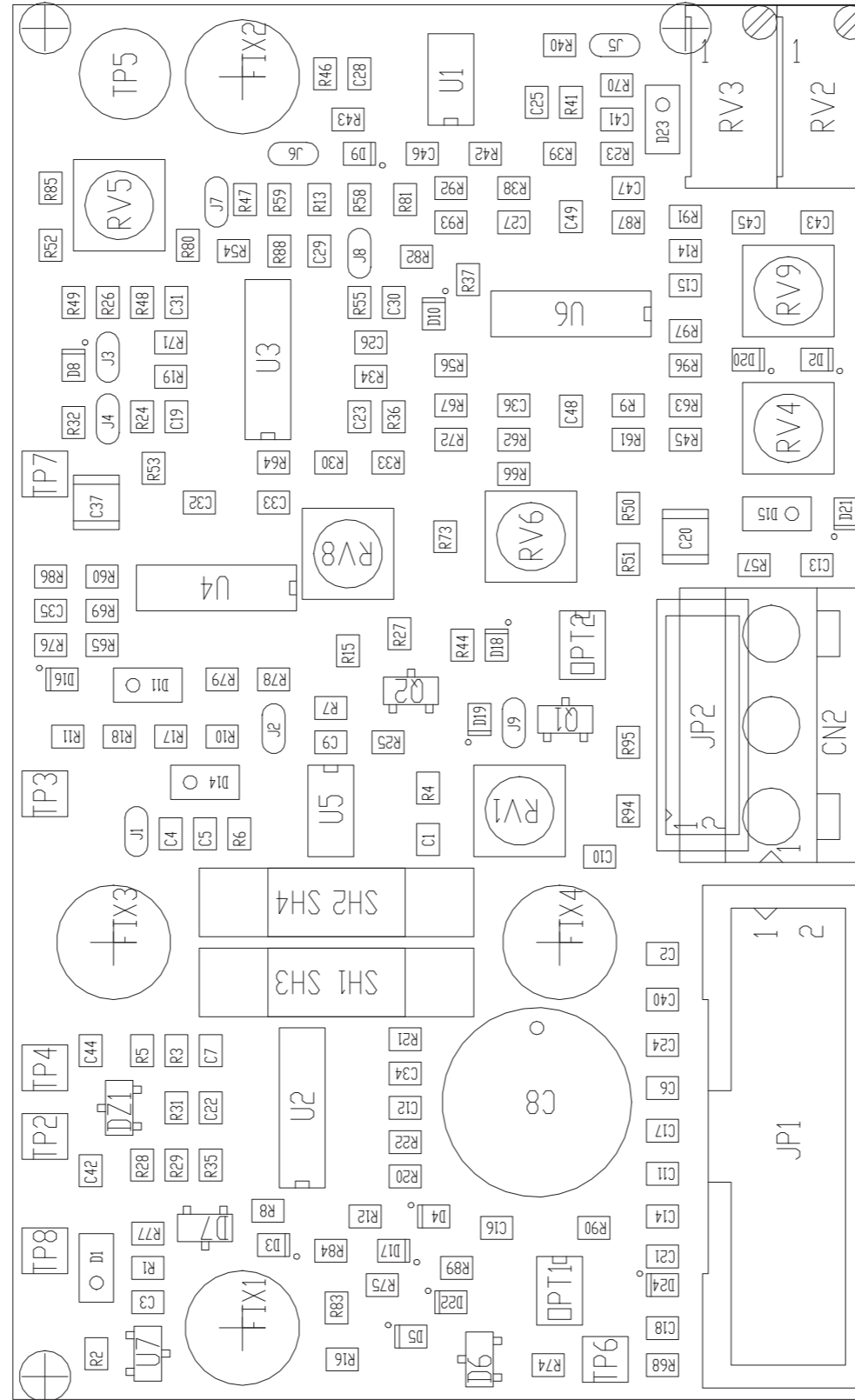

PRODUCT NAME : TEX

DESIGNER : FRANCESCHI A.

ARCHIVING : "RVUT" SERVER, "RILASCIATI" FOLDER

PART NAME : CNTMOS PA RF R.07

DATE : 18/05/16 REVISION : 1.0 SCALE : 1:1 SIZE : A4 PAGE : 1 DI 1

PROJECT CODE : <> DOCUMENT CODE : SLCNTMOS07.**

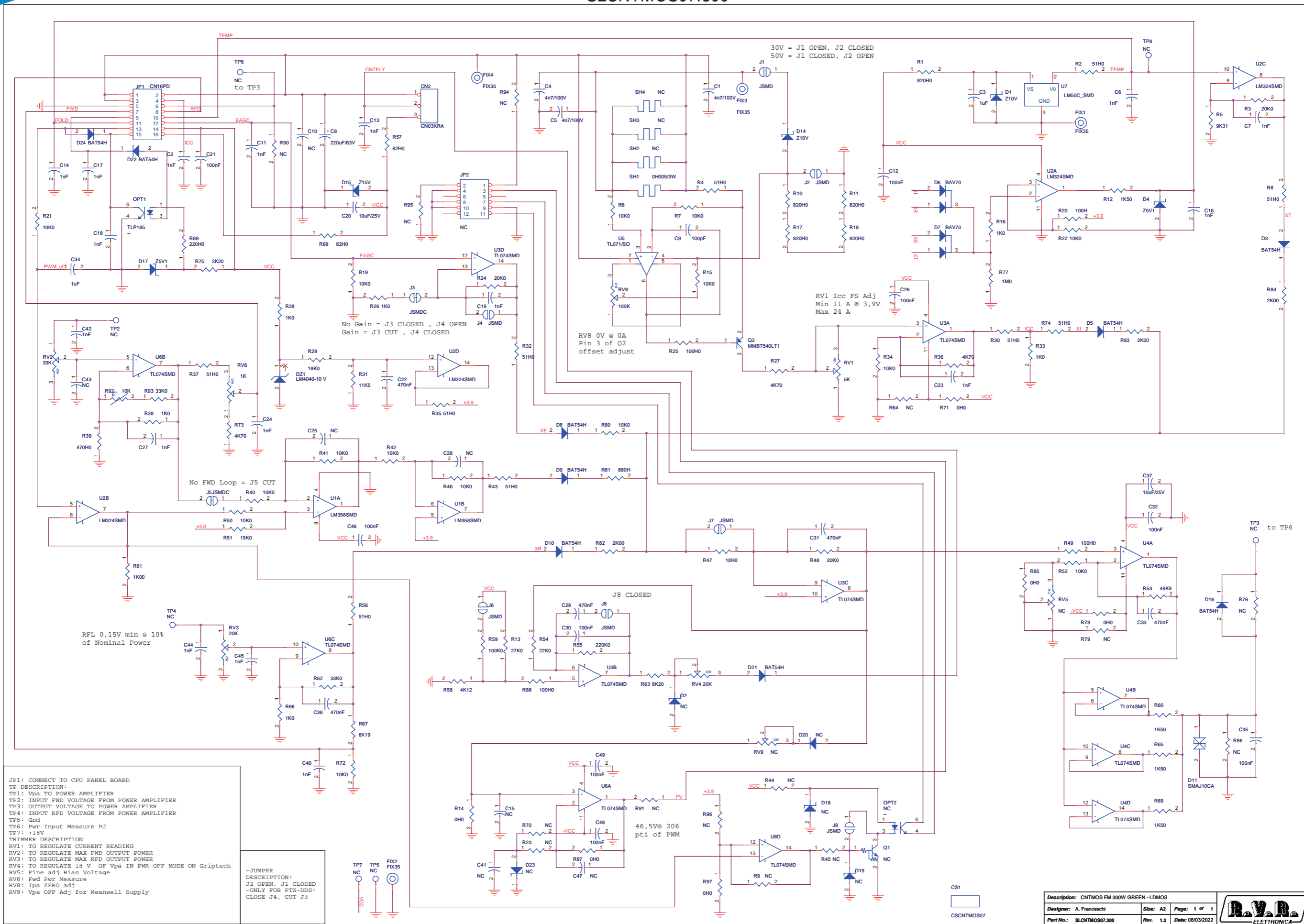

JP1: CONNECT TO CPU PANEL BOARD
 TP DESCRIPTION:
 TP1: V_{pa} TO POWER AMPLIFIER
 TP2: INPUT FWD VOLTAGE FROM POWER AMPLIFIER
 TP3: OUTPUT VOLTAGE TO POWER AMPLIFIER
 TP4: INPUT RFD VOLTAGE FROM POWER AMPLIFIER
 TP5: Gnd
 TP6: Pwr Input Measure PJ
 TP7: +18V
 TRIMMER DESCRIPTION
 RV1: TO REGULATE CURRENT READING
 RV2: TO REGULATE MAX FWD OUTPUT POWER
 RV3: TO REGULATE MAX RFD OUTPUT POWER
 RV4: TO REGULATE 18 V OF V_{pa} IN PWR-OFF MODE ON Griptech
 RV5: Fine adj Bias Voltage
 RV6: Fwd Pwr Measure
 RV8: I_{pa} ZERO adj
 RV9: V_{pa} OFF Adj for Meanwell Supply

-JUMPER
 DESCRIPTION:
 J2 OPEN, J1 CLOSED
 -ONLY FOR PTX-DDS:
 CLOSE J4, CUT J3

Description: CNTMOS FM 300W GREEN - LDMOS		
Designer: A. Franceschi	Size: A2	Page: 1 of 1
Part No.: SLCNTMOS7.300	Rev: 1.3	Date: 08/03/2022



SLCNTMOS07.300

CNTMOS FM 300W GREEN - LDMOS Revised: Tuesday, March 08, 2022
 SLCNTMOS07.300 Revision: 1.3
 A. Franceschi

Item	Quantity	Reference	Part	Description
1	1	CN2	CN03KRA	Conn. tipo KRA a 3 poli
2	1	CS1	CSCNTMOS07	Circuito stampato
3	3	C1, C4, C5	4n7/100V	Cond. SMD 0805
4	17	C2, C6, C7, C11, C13, C14, C16, C17, C18, C19, C23, C24, C27, C40, C42, C44, C45	1nF	Cond. SMD 0805
5	2	C3, C34	1uF	Cond. SMD 0805
6	1	C8	220uF/63V	Cond. Elettr. Dia 10 P5.08
7	1	C9	100pF	Cond. SMD 0805
8	7	C10, C15, C25, C28, C41, C43, C47	NC	Cond. SMD 0805
9	9	C12, C21, C26, C30, C32, C35, C46, C48, C49	100nF	Cond. SMD 0805
10	2	C20, C37	10uF/25V	Cond. SMD 1210
11	5	C22, C29, C31, C33, C36	470nF	Cond. SMD 0805
12	1	DZ1	LM4040-10 V	Diodi Zener SMD SOT23
13	2	D1, D14	Z10V	MINIMELF SMD Zener Diode
14	3	D2, D18, D19	NC	SOD323 Zener Diode
15	9	D3, D5, D8, D9, D10, D16, D21, D22, D24	BAT54H	SOD323 SMD Diode
16	2	D4, D17	Z5V1	SOD323 Zener Diode
17	2	D6, D7	BAV70	Doppio Diode SMD SOT23
18	1	D11	SMAJ10CA	Transzorb SMA
19	1	D15	Z15V	MINIMELF SMD Zener Diode
20	1	D20	NC	SOD323 SMD Diode
21	1	D23	NC	MINIMELF SMD Zener Diode
22	4	FIX1, FIX2, FIX3, FIX4	FIX35	Foro fissaggio 3.5mm
23	1	JP1	CN16PD	Conn.M.C.S.Dritto 16P alette.
24	1	JP2	NC	Conn. 12 poli DF11 12pin p. 2mm
25	7	J1, J2, J4, J6, J7, J8, J9	J5MD	Pad SMD a saldare
26	2	J3, J5	J5MDC	Pad SMD a saldare chiuso
27	1	OPT1	TLP185	Optocoupler SMD SO6
28	1	OPT2	NC	Optocoupler SMD SO6
29	1	Q1	NC	Trans./Res. NPN SOT23
30	1	Q2	MMBT540LT1	Trans. PNP SOT23
31	1	RV1	5K	Trimmer SMD
32	2	RV2, RV3	20K	Trimmer Rg V 3296W
33	1	RV4	20K	Trimmer SMD
34	2	RV5, RV9	NC	Trimmer SMD
35	1	RV6	1K	Trimmer SMD
36	1	RV8	100K	Trimmer SMD
37	5	R1, R10, R11, R17, R18	820H0	Res. SMD 0805 1%
38	10	R2, R4, R8, R30, R32, R35, R37, R43, R56, R74	51H0	Res. SMD 0805 1%
39	3	R3, R24, R48	20K0	Res. SMD 0805 1%
40	1	R5	9K31	Res. SMD 0805 1%
41	15	R6, R7, R15, R19, R21, R22, R34, R40, R41, R42, R46, R50, R52, R72, R80	10K0	Res. SMD 0805 1%
42	14	R9, R23, R44, R45, R64, R70, R76, R79, R86, R90, R91, R94, R95, R96	NC	Res. SMD 0805 1%
43	4	R12, R60, R65, R69	1K50	Res. SMD 0805 1%
44	1	R13	27K0	Res. SMD 0805 1%
45	6	R14, R71, R78, R85, R87, R97	0H0	Res. SMD 0805 1%
46	6	R16, R26, R28, R33, R38, R66	1K0	Res. SMD 0805 1%
47	1	R20	100H	Res. SMD 0805 1%
48	3	R25, R49, R88	100H0	Res. SMD 0805 1%
49	3	R27, R36, R73	4K70	Res. SMD 0805 1%
50	1	R29	18K0	Res. SMD 0805 1%
51	1	R31	11K5	Res. SMD 0805 1%
52	1	R39	470H0	Res. SMD 0805 1%
53	1	R47	10H0	Res. SMD 0805 1%
54	1	R51	15K0	Res. SMD 0805 1%
55	1	R53	49K9	Res. SMD 0805 1%
56	1	R54	22K0	Res. SMD 0805 1%
57	1	R55	220K0	Res. SMD 0805 1%
58	2	R57, R68	82H0	Res. SMD 0805 1%
59	1	R58	4K12	Res. SMD 0805 1%
60	1	R59	100K0	Res. SMD 0805 1%
61	1	R61	1K00	Res. SMD 0805 1%
62	2	R62, R93	33K0	Res. SMD 0805 1%
63	1	R63	8K20	Res. SMD 0805 1%
64	1	R67	6K19	Res. SMD 0805 1%
65	1	R75	2K20	Res. SMD 0805 1%
66	1	R77	1M0	Res. SMD 0805 1%

Item	Quantity	Reference	Part	Description
67	1	R81	680H	Res. SMD 0805 1%
68	3	R82, R83, R84	2K00	Res. SMD 0805 1%
69	1	R89	220H0	Res. SMD 0805 1%
70	1	R92	10K	Res. NTC SMD 0805
71	1	SH1	0H005/3W	Shunt passo 15.2mm fori 2mm
72	1	SH2	NC	Shunt passo 15.2mm fori 2mm
73	2	SH3, SH4	NC	Shunt SMD 2512
74	6	TP2, TP3, TP4, TP6, TP7, TP8	NC	Foro dia. 1mm
75	1	TP5	NC	Foro dia. 2mm
76	1	U1	LM358SMD	Dual Op. SMD SO8
77	1	U2	LM324SMD	Quad Op. SMD SO14
78	3	U3, U4, U6	TL074SMD	Quad Op. SMD SO14
79	1	U5	TL071/SO	Single Op. SMD SO8
80	1	U7	LM50C_SMD	Temperature sensor

SLPS0468R01V02

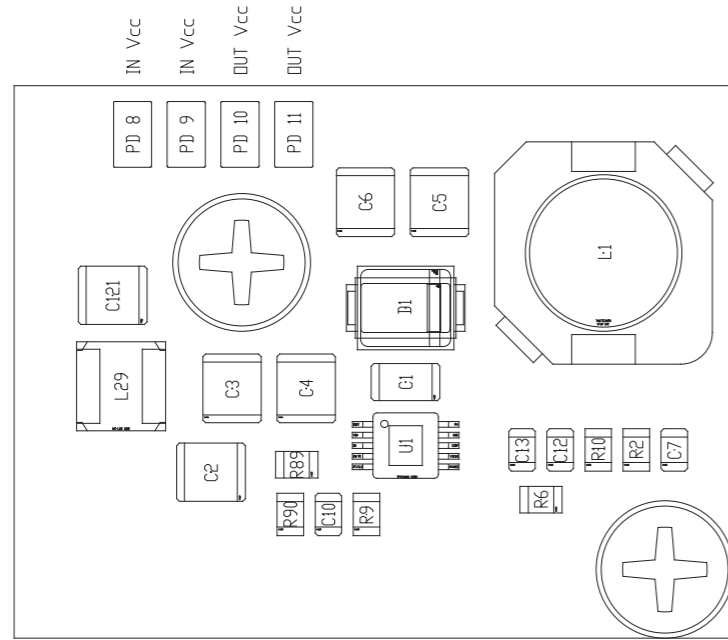

DESCRIPTION : POWER SUPPLY PA RF 50W 50V



PART CODE : SLPS0468R01V**

DATE: 19/04/2017 | REVISION: 1.0 | SCALE: 3:1 | SIZE: A4 | PAGINA: 1 DI 1

DESIGNER : FRANCESCHI A.

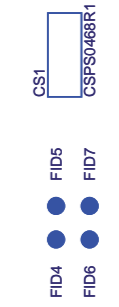
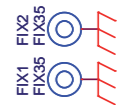
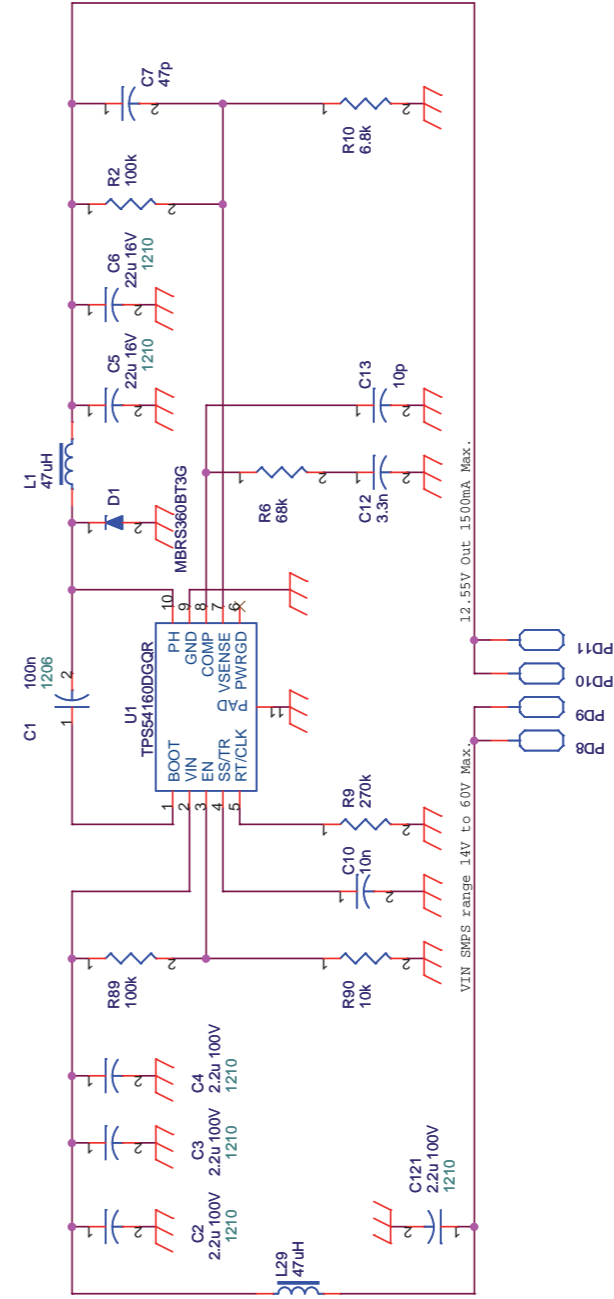

Description: POWER SUPPLY PA RF 50V 1A5	
Designer: Mauro Ucelli	Size: A4
Part No.: SLPS0468R01V02	Page: 1 of 1
Rev. 1.0	Date: 11/03/2019

SLPS0468R01V02

POWER SUPPLY PA RF 50V 1A5
 SLPS0468R01V02
 Revision: 1.0
 11/03/2019
 Mauro Ucelli

Item	Quantity	Reference	Part	Description
1	1	CS1	CSPS0468R1	Circuito stampato PA
2	1	C1	100n	Cond. SMD 1206
3	4	C2,C3,C4,C121	2.2u 100V	Capacitor SMD 1210 MLCC X7R 100V
4	2	C5,C6	22u 16V	Capacitor SMD 1210 MLCC X7R 16V
5	1	C7	47p	Cond. SMD 0805 COG
6	1	C10	10n	SMD 0805 MLCC X7R
7	1	C12	3.3n	SMD 0805 MLCC X7R
8	1	C13	10p	Cond. SMD 0805 COG
9	1	D1	MBRS360BT3G	SMB Size SCHOTTKY Diode
10	4	FID4,FID5,FID6,FID7	FID	Fiducial CS
11	2	FIX1,FIX2	FIX35	
12	1	L1	47uH	PWR Ind Wurth E 7447714470
13	1	L29	47uH	PWR Ind WE 74404042470
14	4	PD8,PD9,PD10,PD11	PAD	Pad for connection
15	2	R2,R89	100k	Res. SMD 0805
16	1	R6	68k	Res. SMD 0805
17	1	R9	270k	Res. SMD 0805
18	1	R10	6.8k	Res. SMD 0805
19	1	R90	10k	Res. SMD 0805
20	1	U1	TPS54160DGQR	Step-Down DC2DC Converter

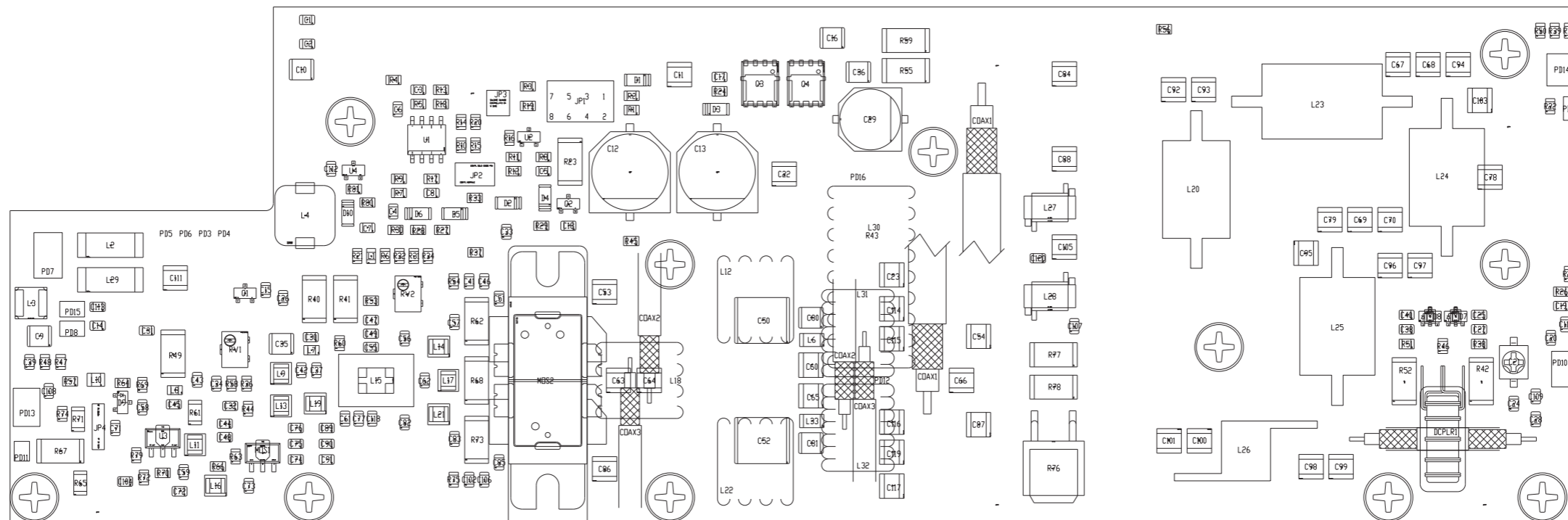

DESCRIPTION : RF PA 300W FM BAND

PART CODE : SLRF0484R03V01

DESIGNER : M. UCELLI

DATE: 13/10/2021 | REVISION: 1.0 | SCALE: 1:1 | SIZE: A4 | PAGINA: 1 DI 1

SLRF0484R03V01

PA 300W FM Revised: 03/03/2022
 SLRF0484R03V01 Revision: 1.1
 Mauro Ucelli

Item	Quantity	Reference	Part	Description
1	1	COAX1	COAX_LINE	Coax cable
2	2	COAX2, COAX3	COAX_U_LINE	U coax cable
3	1	C51	CSRFO484R3	Printed Circuit board
4	11	C1, C2, C7, C15, C25, C26, C31, C34, C39, C40, C49	4n7	0805 SMD capacitor
5	2	C3, C8	10n	0805 SMD capacitor
6	1	C4	22p	0805 COG SMD capacitor
7	16	C5, C19, C20, C24, C27, C38, C51, C56, C57, C73, C82, C83, C85, C110, C118, C120	NC	0805 COG SMD capacitor
8	4	C6, C41, C106, C112	100n	0805 SMD capacitor
9	1	C9	22u 16V	Capacitor SMD 1210 MLCC X7R 16V
10	2	C10, C16	220n 100V	Capacitor SMD 1210 MLCC X7R 100V
11	3	C11, C22, C111	1n	1212 HQ SMD capacitor
12	2	C12, C13	100u 63V	SMD electr. cap. 10mm
13	17	C14, C17, C18, C30, C32, C33, C42, C45, C46, C48, C55, C58, C71, C102, C104, C108,	1n	0805 COG SMD capacitor
14	2	C28, C109	1p 200V	0805 COG SMD capacitor
15	1	C21	7/50p	Adj. Cap 7 / 50pF
16	9	C23, C53, C54, C63, C64, C66, C86, C87, C117	NC	1212 HQ SMD capacitor
17	1	C29	47u 63V	SMD electr. cap. 10mm
18	1	C35	2.2u	Capacitor SMD 1210 MLCC X7R 100V
19	1	C36	1u	Capacitor SMD 1210 MLCC X7R 100V
20	4	C37, C43, C44, C47	22n	0805 SMD capacitor
21	2	C50, C52	1u	Cap. PolyE. SMD size 2824 100VDC
22	1	C59	270p	0805 COG SMD capacitor
23	6	C60, C65, C114, C115, C116, C119	470p	1212 HQ SMD capacitor
24	2	C61, C77	470p	0805 COG SMD capacitor
25	1	C62	39p	0805 COG SMD capacitor
26	8	C67, C79, C88, C92, C93, C97, C99, C103	12p	1212 HQ SMD capacitor
27	6	C68, C69, C70, C94, C95, C96	15p	1212 HQ SMD capacitor
28	1	C72	68p	0805 COG SMD capacitor
29	3	C74, C75, C76	27p	0805 COG SMD capacitor
30	2	C78, C101	6p8	1212 HQ SMD capacitor
31	2	C80, C81	NC	Capacitor SMD 1210 MLCC X7R 100V
32	1	C84	8p2	1212 HQ SMD capacitor
33	3	C89, C90, C91	15p	0805 COG SMD capacitor
34	2	C98, C100	10p	1212 HQ SMD capacitor
35	1	C105	3p3	1212 HQ SMD capacitor
36	1	C107	6p8	0805 COG SMD capacitor
37	1	DCPLR1	DIR_CPLR	Directional coupler
38	1	D1	15V	MINIMELF SMD Zener Diode
39	3	D2, D4, D5	BAS32	MINIMELF SMD Diode
40	2	D3, D10	9V1	MINIMELF SMD Zener Diode
41	1	D6	4V7	MINIMELF SMD Zener Diode
42	2	D7, D8	BAS70	Hot Carrier Schottky Diode
43	1	D9	BA779-G	SOT23 Pin Diode
44	6	FID1, FID2, FID3, FID4, FID5, FID6	FID	PCB fiducial
45	11	FIX1, FIX2, FIX3, FIX4, FIX5, FIX6, FIX7, FIX8, FIX9, FIX10, FIX11	FIX35	
46	1	JP1	Bias Sel	Male strip 4+4 pin
47	1	JP2	Bias Sel	*
48	1	JP3	Hyst Sel	*
49	1	JP4	RF Level	*
50	3	L1, L7, L8	WE 742792022	Ferrite Bead 0805
51	2	L2, L29	WE 74279225101	Ferrite Bead 3412
52	1	L3	47uH	PWR Ind WE 74404042470
53	1	L4	2.2uH	PWR Ind WE 7443340220
54	2	L6, L33	742792115	Ferrite Bead 1206
55	3	L9, L13, L19	47n	SMD inductor HQ 2520 (1008)
56	1	L10	470n	SMD inductor HQ 2012 (0805)
57	1	L11	68n	SMD inductor HQ 2520 (1008)
58	2	L12, L22	NC	? Spire Filo R-Arg. D. 7mm avvolte su D. 7mm lunghezza 7mm
59	3	L14, L16, L21	27n	SMD inductor HQ 2520 (1008)
60	1	L15	744235601	WE-CNSW SMD Common Mode Line Filter
61	1	L17	33n	SMD inductor HQ 2012 (0805)
62	1	L18	80n	2.5 Spire Filo R-Arg. D. 1.5mm avvolte su D. 9mm lunghezza 6.5mm
63	1	L20	100n	5 Spire Filo R-Arg. D. 1mm avvolte su D. 6.5mm lunghezza 12mm
64	1	L23	97n	5 Spire Filo R-Arg. D. 1.5mm avvolte su D. 6.5mm lunghezza 11mm
65	1	L24	78n	4 Spire Filo R-Arg. D. 1.5mm avvolte su D. 6.5mm lunghezza 9mm
66	1	L25	75n	4 Spire Filo R-Arg. D. 1.5mm avvolte su D. 6.5mm lunghezza 9.5mm
67	1	L26	45n	3 Spire Filo R-Arg. D. 1mm avvolte su D. 5mm lunghezza 5.5mm
68	1	L27	22n	Air Coil Ind WE 744914122
69	1	L28	35n	Air Coil Ind WE 744912133
70	1	L30	200u	10spire filo R. Smalt. 2mm Avvolte su 6mm
71	2	L31, L32	NC	? Spire Filo R.Smalt. D. 7mm avvolte su D. 7mm lunghezza 7mm
72	1	MOS1	AFT05MS004N	RF Power LDMOS Transistor SOT-89
73	1	MOS2	MRF6VP6600N	RF Power LDMOS Transistors Push-Pull
74	14	PD1, PD2, PD3, PD4, PD5, PD6, PD7, PD8, PD9, PD10, PD11, PD13, PD14, PD15	PAD	SMD pad
75	2	PD12, PD16	PAD	Pad for connection
76	1	Q1	A03407A	SOT23 PMOS

Item	Quantity	Reference	Part	Description
77	1	Q2	BSS123L	SOT23 NMOS
78	2	Q3, Q4	SI7469DP	P-Channel 80-V (D-S) MOSFET
79	2	RV1, RV2	10k	Trimmer SMD V 3314
80	1	R1	18k	0805 SMD res.
81	1	R2	5k6	0805 SMD res.
82	2	R3, R46	2k2	0805 SMD res.
83	4	R4, R12, R16, R58	1k0	0805 SMD res.
84	1	R5	8k2	0805 SMD res.
85	4	R6, R19, R72, R81	100R	0805 SMD res.
86	3	R7, R8, R79	10R	0805 SMD res.
87	4	R9, R13, R24, R29	10k	0805 SMD res.
88	3	R10, R14, R53	470R	0805 SMD res.
89	1	R11	2k	0805 SMD res.
90	1	R15	2k7	0805 SMD res.
91	1	R17	27k	0805 SMD res.
92	2	R18, R69	560R	0805 SMD res.
93	1	R20	120R	0805 SMD res.
94	1	R21	6k8	0805 SMD res.
95	1	R23	4k7	2512 1% SMD res.
96	9	R22, R25, R26, R27, R28, R32, R60, R64, R70	NC	0805 SMD res.
97	3	R30, R39, R50	15k	0805 SMD res.
98	2	R31, R48	3k3	0805 SMD res.
99	2	R33, R34	0R	0805 SMD res.
100	2	R35, R56	4k99	0805 SMD res.
101	1	R36	33k	0805 SMD res.
102	1	R37	39k	0805 SMD res.
103	4	R38, R47, R51, R57	47R	0805 SMD res.
104	4	R40, R41, R55, R59	3R3	2512 1% SMD res.
105	2	R42, R52	51R	2512 1% SMD res.
106	1	R43	22R 2W	2W resistor
107	2	R44, R45	10k	NTC resistor SMD 0805
108	1	R49	100R	2512 1% SMD res.
109	2	R54, R75	220k	0805 SMD res.
110	1	R61	4R7	1206 SMD res.
111	2	R62, R73	150R	2512 1% SMD res.
112	1	R63	22R	0805 SMD res.
113	1	R65	100R	1206 SMD res.
114	1	R66	100k	0805 SMD res.
115	1	R67	22R	2512 1% SMD res.
116	1	R68	82R	2512 1% SMD res.
117	1	R71	22R	1206 SMD res.
118	1	R74	3R9	0805 SMD res.
119	1	R76	50R	DPAK resistor
120	2	R77, R78	NC	2512 1% SMD res.
121	1	R80	330R	0805 SMD res.
122	1	U1	LMC6482	Rail to Rail Dual Op. SMD SO8
123	1	U2	TLV431	Low Volt. Adj. Shunt Reg 1.24Vref
124	1	U3	GALI-5+	RF MMIC
125	1	U4	LM50C_SMD	Temperature sensor
126	1	W1	NC	Filo D. 0.5mm lungo 5mm

SLPC0463R05V01

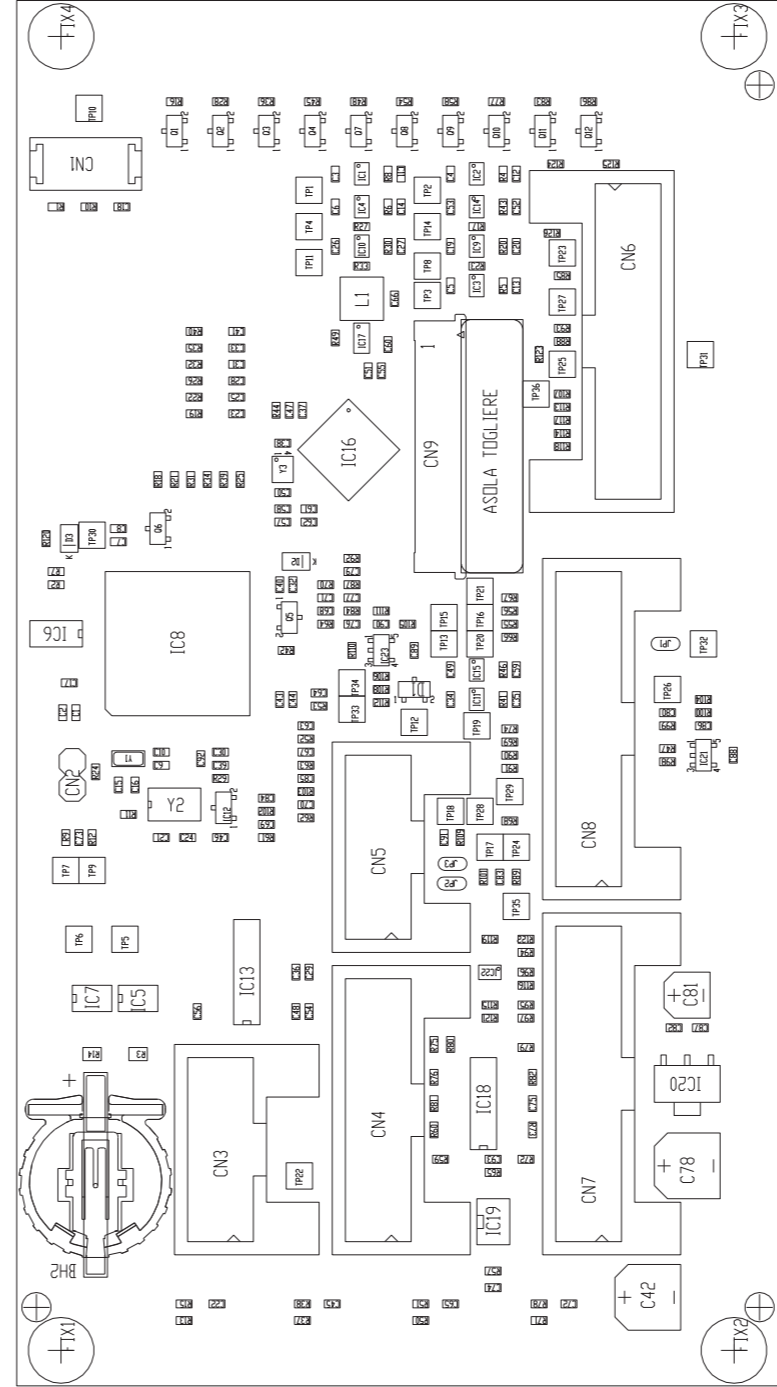
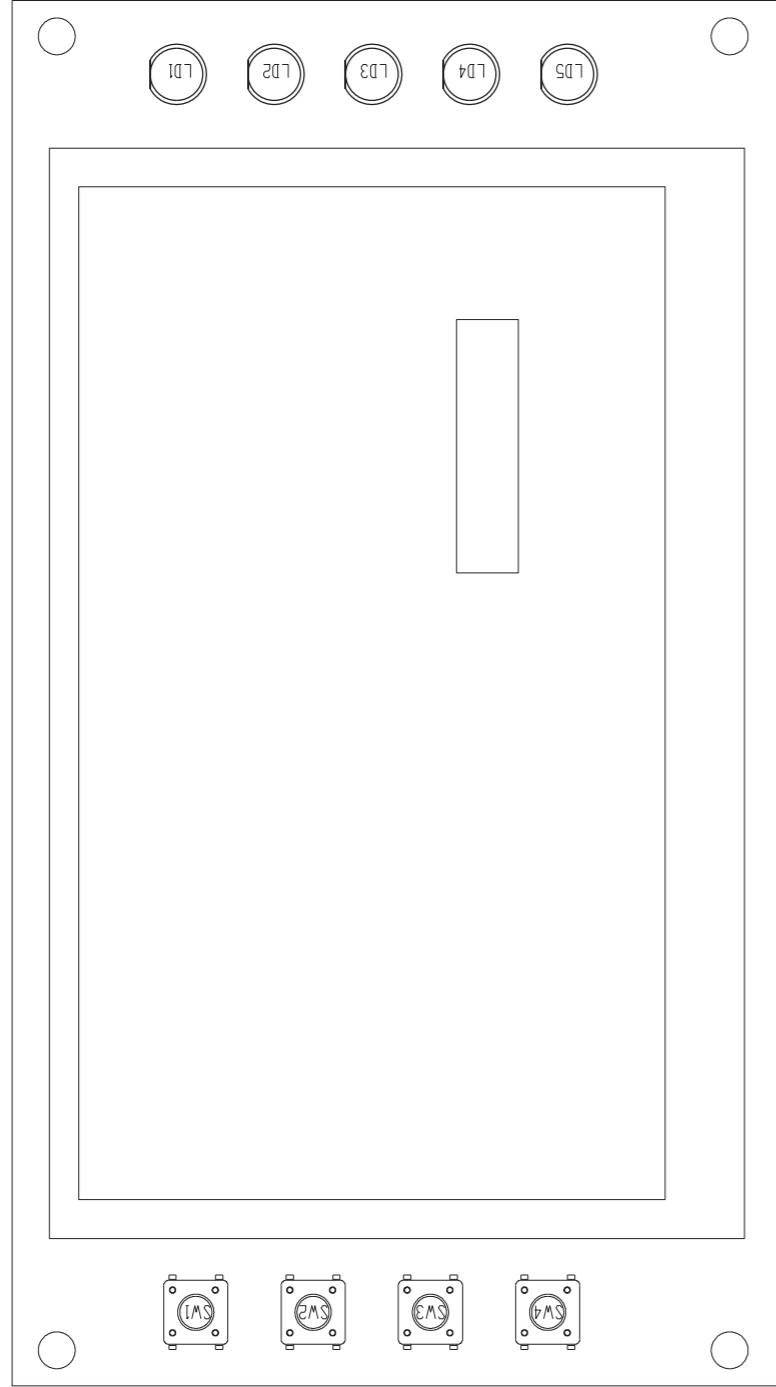

PRODUCT NAME : TEX-TFT

PART NAME : Touch Screen Panel Card

DESIGNER : FRANCESCHI A.

DATE : 16/03/22 REVISION : 1.0 SCALE : 1:1 SIZE : A4 PAGE : 1 DI 1

ARCHIVING : "RVPUT" SERVER, "RILASCIATI" FOLDER

PROJECT CODE : 252

DOCUMENT CODE : SLPC0463R05V**

SLPC0463R05V01

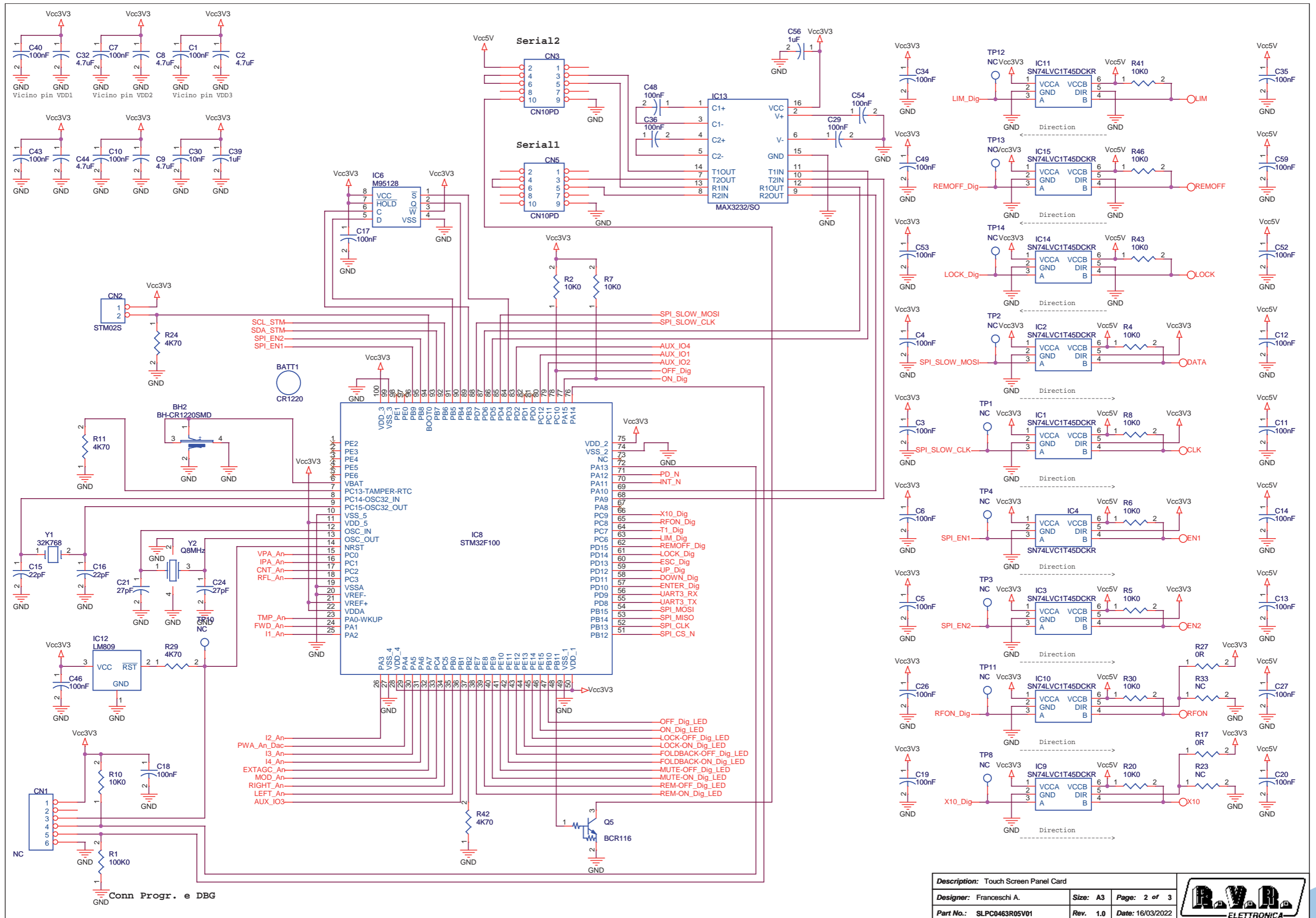

Description: Touch Screen Panel Card			
Designer: Franceschi A.	Size: A3	Page: 2 of 3	
Part No.: SLPC0463R05V01	Rev.: 1.0	Date: 16/03/2022	

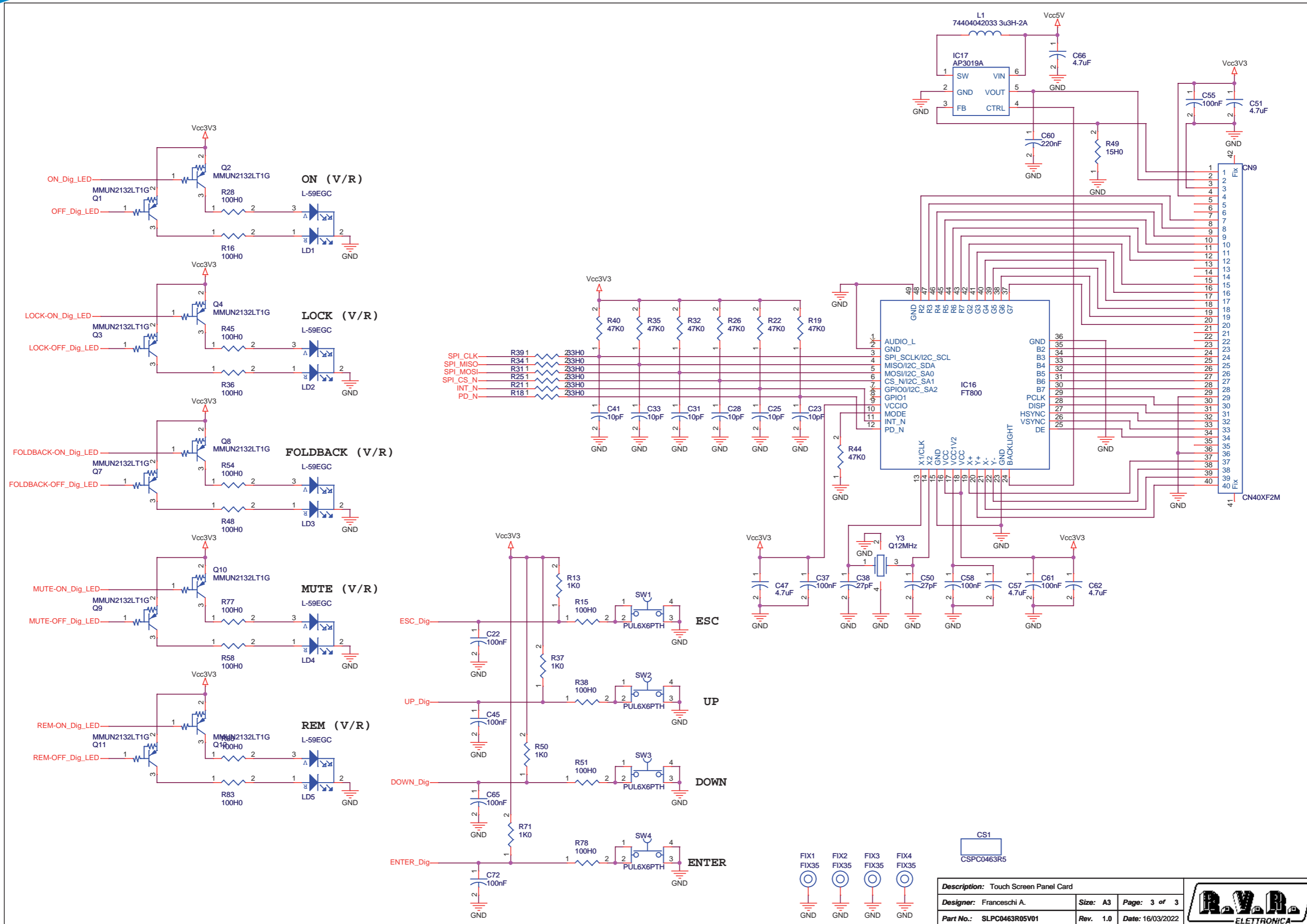

Description: Touch Screen Panel Card		
Designer: Franceschi A.	Size: A3	Page: 3 of 3
Part No.: SLPC0463R05V01	Rev.: 1.0	Date: 16/03/2022



SLPC0463R05V01

Touch Screen Panel Card Revised: 16/03/2022
 SLPC0463R05V01 Revision: 1.0
 Franceschi A.

Item	Quantity	Reference	Part	Description
1	1	BATT1	CR1220	CR1220 Lithium Battery
2	1	BH2	BH-CR1220SMD	CR1220 SMD Battery holder
3	1	CN1	NC	6 way PTH Micromatch connector
4	1	CN2	STM02S	Male strip 2 pin
5	2	CN3, CN5	CN10PD	10 way pcb conn.
6	1	CN4	CN16PD	16 way pcb conn.
7	3	CN6, CN7, CN8	CN16PD	16 way pcb conn.
8	1	CN9	CN40XF2M	40 way ZIF conn. pitch 0,5mm
9	1	CS1	CSPC0463R4	Printed Circuit board
10	61	C1, C3, C4, C5, C6, C7, C10, C11, C12, C13, C14, C17, C18, C19, C20, C22, C26, C27, C29, C34, C35, C36, C37, C40, C43, C45, C46, C48, C49, C52, C53, C54, C55, C58, C59, C61, C63, C64, C65, C67, C68, C69, C70, C71, C72, C73, C74, C75, C76, C77, C79, C82, C83, C84, C85, C87, C88, C89, C91, C92, C93	100nF	0603 SMD capacitor
11	10	C2, C8, C9, C32, C44, C47, C51, C57, C62, C66	4.7uF	0603 SMD capacitor
12	2	C15, C16	22pF	0603 SMD capacitor
13	4	C21, C24, C38, C50	27pF	0603 SMD capacitor
14	6	C23, C25, C28, C31, C33, C41	10pF	0603 SMD capacitor
15	1	C30	10nF	0603 SMD capacitor
16	2	C39, C56	1uF	0603 SMD capacitor
17	2	C42, C78	47uF/35V	SMD electr. cap. 6.3mm
18	1	C60	220nF	0603 SMD capacitor
19	1	C80	NC	0603 SMD capacitor
20	1	C81	10uF/16V	SMD electr. cap. 4mm
21	2	C86, C90	1nF	0603 SMD capacitor
22	1	D1	ADR512	SMD SOT23 precision Zener
23	2	D2, D3	Z3V3	SOD123F Zener Diode
24	4	FIX1, FIX2, FIX3, FIX4	FIX35	3.5mm Fixing hole
25	9	IC1, IC2, IC3, IC4, IC9, IC10, IC11, IC14, IC15	SN74LVC1T45DCKR	Bidirect. level translator
26	2	IC5, IC7	SFH690	Optocoupler SMD SO6
27	1	IC6	M95128	SMD Serial EEPROM
28	1	IC8	STM32F100	STM32F100 Microcontroller
29	1	IC12	LM809-2.93	uC supervisor
30	1	IC13	MAX3232/SO	SO16 RS232 driver
31	1	IC16	FT800	Display controller
32	1	IC17	AP3019A	Switching LED driver
33	1	IC18	LM324/SO	Quad Op. SMD SO14
34	1	IC19	82B96/SSOP	SMD IIC Bus driver
35	1	IC20	LM1117MP-3.3V	Voltage reg. SMD SOT223
36	2	IC21, IC23	MCP601T-I/OT	Single Op Amp SOT23-5
37	1	IC22	SMF05C	TVS Diode array
38	3	JP1, JP2, JP3	J5MD	2 pad SMD jumper
39	5	LD1, LD2, LD3, LD4, LD5	L-59EGC	Two-color led common Cathode 5mm
40	1	L1	74404042033 3u3H-2A	WE LQ540 series inductor
41	10	Q1, Q2, Q3, Q4, Q7, Q8, Q9, Q10, Q11, Q12	MMUN2132LT1G	Digital PNP trans. SOT23
42	2	Q5, Q6	BCR116	Digital NPN trans. SOT23
43	1	R1	100K0	0603 SMD res.
44	32	R2, R4, R5, R6, R7, R8, R9, R10, R12, R20, R30, R41, R43, R46, R55, R56, R57, R65, R66, R67, R68, R69, R74, R81, R85, R88, R90, R91, R93, R98, R104, R110	10K0	0603 SMD res.
45	2	R3, R14	1K80	0805 SMD res.
46	8	R11, R24, R29, R42, R59, R72, R79, R80	4K70	0603 SMD res.
47	4	R13, R37, R50, R71	1K0	0603 SMD res.
48	19	R15, R16, R28, R36, R38, R45, R48, R51, R54, R58, R77, R78, R83, R86, R99, R123, R124, R125, R126	100H0	0603 SMD res.
49	2	R17, R27	0R	0603 SMD res.
50	6	R18, R21, R25, R31, R34, R39	33H0	0603 SMD res.
51	7	R19, R22, R26, R32, R35, R40, R44	47K0	0603 SMD res.
52	2	R23, R33	NC	0603 SMD res.
53	1	R47	1M	0603 SMD res.
54	1	R49	15H0	0603 SMD res.
55	12	R52, R53, R61, R62, R63, R64, R70, R84, R87, R92, R102, R103	20K0	0603 SMD res.
56	12	R60, R73, R75, R82, R94, R95, R96, R97, R113, R114, R117, R118	22H0	0603 SMD res.
57	1	R76	5K10	0603 SMD res.
58	2	R89, R107	22K0	0603 SMD res.
59	1	R100	4K99	0603 SMD res.
60	2	R101, R109	1K50	0603 SMD res.
61	2	R105, R106	220K0	0603 SMD res.
62	2	R108, R112	12K0	0603 SMD res.
63	1	R111	1K20	0603 SMD res.
64	6	R115, R116, R119, R120, R121, R122	3K30	0603 SMD res.
65	4	SW1, SW2, SW3, SW4	PUL6X6PTH	PCB PTH pushbutton
66	36	TP1, TP2, TP3, TP4, TP5, TP6, TP7, TP8, TP9, TP10, TP11, TP12, TP13, TP14, TP15, TP16, TP17, TP18, TP19, TP20, TP21, TP22, TP23, TP24, TP25, TP26, TP27, TP28, TP29, TP30, TP31, TP32, TP33, TP34, TP35, TP36	NC	Test point
67	1	Y1	32K768	SMD Crystal 3.2x1.5 mm
68	1	Y2	Q8MHz	SMD Crystal NX5032SA
69	1	Y3	Q12MHz	SMD Crystal 2x2.5 mm

KPSL5012R01A

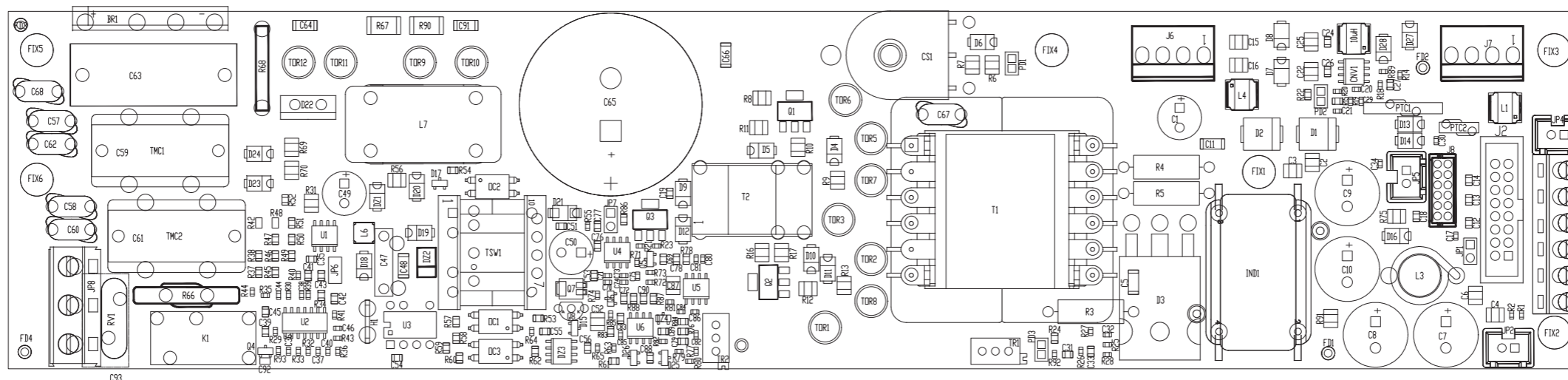

	PRODUCT NAME : TEX300LCD	PART NAME : POWER SUPPLY 50V PFC			
	DESIGNER : UT	DATE : 18/07/18	REVISION : 1.0	SCALE : 1:1	SIZE : A3
ARCHIVING : *RVRUT* SERVER, *RILASCIATI* FOLDER	PROJECT CODE : <	DOCUMENT CODE : KPSL5012R01A			

KPSL5012R01A

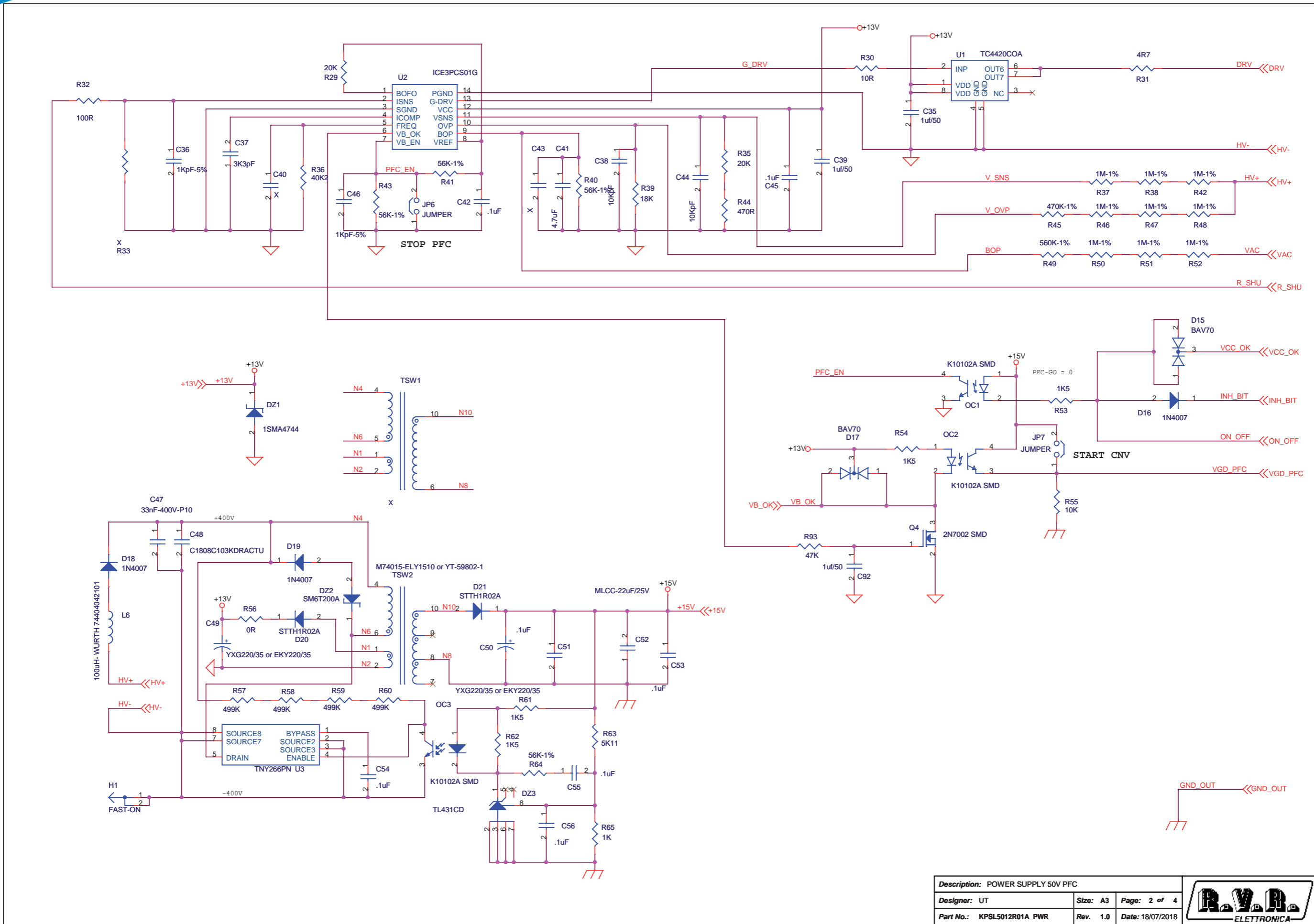

Description: POWER SUPPLY 50V PFC		
Designer: UT	Size: A3	Page: 2 of 4
Part No.: KPSL5012R01A_PWR	Rev. 1.0	Date: 18/07/2018



KPSL5012R01A

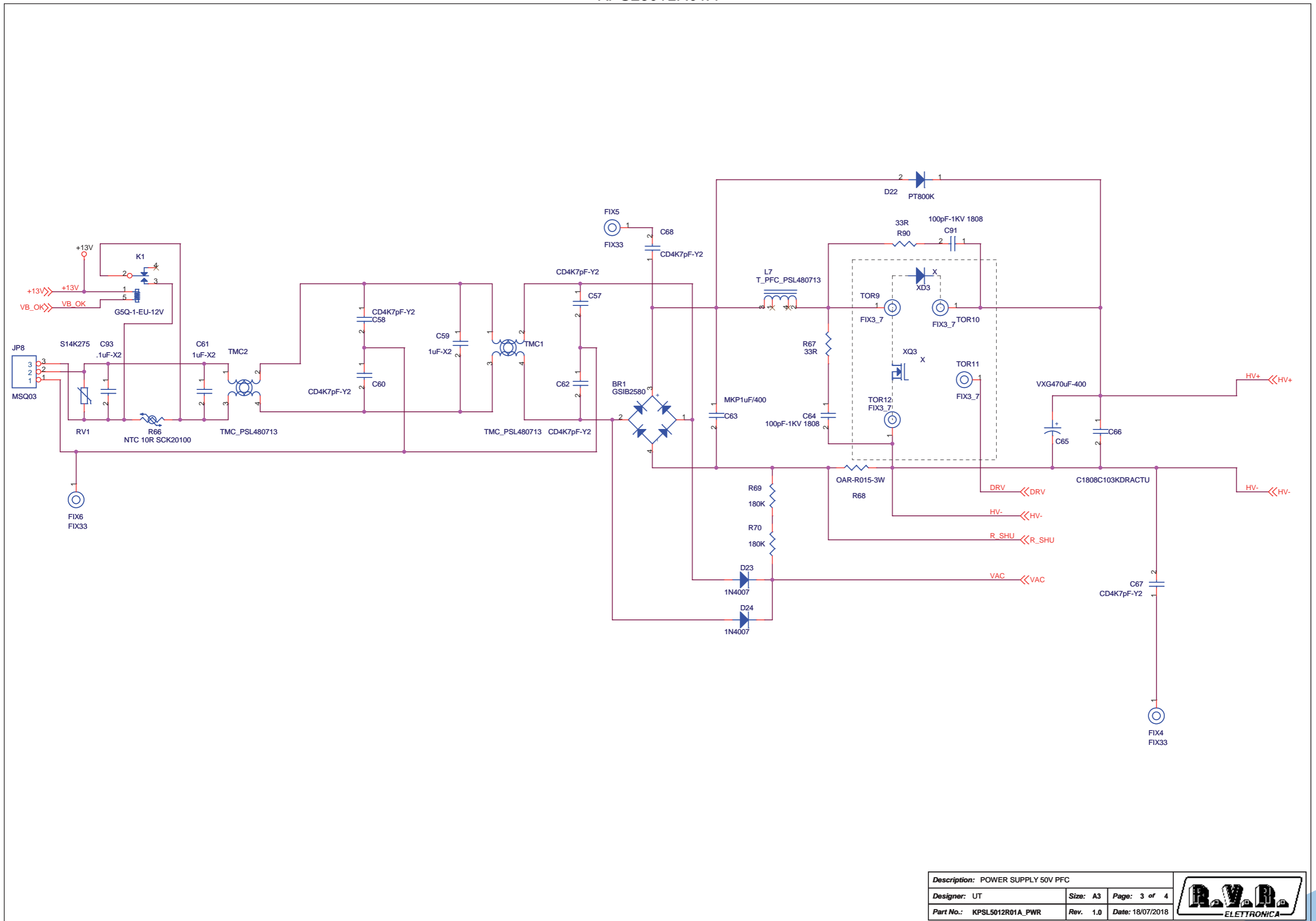

Description: POWER SUPPLY 50V PFC			
Designer: UT	Size: A3	Page: 3 of 4	
Part No.: KPSL5012R01A_PWR	Rev. 1.0	Date: 18/07/2018	

KPSL5012R01A

POWER SUPPLY 50V PFC Revised: 18/07/2018
 KPSL5012R01A_PWR Revision: 1.0
 UT

Item	Quantity	Reference	Part
1	1	BR1	GSIB2580
2	1	CNV1	NCP3170ADR2G
3	1	CS1	PE-51718-M28908
4	3	C1, C49, C50	YXG220/35 or EKY220/35
5	6	C2, C3, C4, C6, C15, C16	2.2uF-100V-C1210C225K1RACTU
6	2	C5, C11	1KpF
7	4	C7, C8, C9, C10	470uF/63
8	21	C12, C13, C14, C18, C24, C26, C27, C31, C42, C45, C51, C53, C54, C55, C56, C72, C76, C78, C83, C89, C90	.1uF
9	6	C17, C30, C34, C36, C46, C75	1KPF-5%
10	6	C19, C35, C39, C77, C88, C92	1uf/50
11	5	C20, R33, C40, C71, C73	X
12	2	C21, C86	100pF
13	4	C22, C25, C52, C87	MLCC-22uF/25V
14	5	C29, C80, C81, C82, C85	4K7pF
15	1	C32	XX
16	2	C33, C43	X
17	1	C37	3K3pF
18	3	C38, C44, C70	10KPF
19	1	C41	4.7uF
20	1	C47	33nF-400V-P10
21	2	C48, C66	C1808C103KDRACTU
22	6	C57, C58, C60, C62, C67, C68	CD4K7pF-Y2
23	2	C59, C61	1uF-X2
24	1	C63	MKP1uF/400
25	2	C64, C91	100pF-1KV 1808
26	1	C65	VXG470uF-400
27	1	C74	330pF
28	1	C79	10uF/16
29	1	C84	47pF
30	1	C93	.1uF-X2
31	2	DZ1, D9	1SMA4744
32	1	DZ2	SM6T200A
33	1	DZ3	TL431CD
34	1	DZ4	LM4040-5V-1%
35	2	D1, D2	STTH3R02S
36	1	D3	VS-HFA50PA60CPBF
37	7	D4, D5, D10, D11, D12, D13, D28	B140-E3
38	3	D6, D20, D21	STTH1R02A
39	7	D7, D14, D16, D18, D19, D23, D24	1N4007
40	2	D8, D27	S3J
41	4	D15, D17, D25, D26	BAV70
42	1	D22	PT800K
43	1	D29	1N4007
44	4	FD1, FD2, FD3, FD4	FIDUCIAL
45	6	FIX1, FIX2, FIX3, FIX4, FIX5, FIX6	FIX33
46	1	H1	FAST-ON
47	1	IND1	T_PSL480713
48	3	JP1, JP6, JP7	JUMPER
49	3	JP2, JP4, JP5	2.5MSF2
50	1	JP3	MSQ6
51	1	JP8	MSQ03
52	1	J2	CON16AP
53	1	J6	MOLEX 4
54	1	J7	MOLEX-4
55	1	J8	DF11-12DP-2DSA
56	1	K1	G5Q-1-EU-12V
57	3	L1, L4, L5	10uH 744 040 641 00
58	1	L3	BFV0710

Item	Quantity	Reference	Part
59	1	L6	100uH- WURTH 74404042101
60	1	L7	T_PFC_PSL480713
61	3	OC1, OC2, OC3	K10102A SMD
62	1	PD1	LUNENO
63	1	PD2	+6.5V
64	1	PD3	PSL300
65	2	PD4, PD5	PAD
66	1	PTC2	RXE040
67	2	Q1, Q2	FZT792A
68	1	Q3	IRLL110BF
69	1	Q4	2N7002 SMD
70	1	Q5	BC847
71	1	Q6	BCR135
72	1	Q7	S4S2RP
73	1	Q8	2N5064
74	1	RV1	S14K275
75	8	R1, R2, R19, R23, R26, R55, R74, R85	10K
76	3	R3, R4, R5	100R-2W
77	4	R6, R9, R13, R31	4R7
78	1	R7	15R
79	2	R8, R12	47R
80	2	R10, R16	10R
81	2	R11, R17	330R
82	2	R14, R39	18K
83	2	R15, R24	24K9
84	3	R18, R27, R82	3K01
85	3	R20, R25, R73	4K75
86	3	R21, R30, R80	10R
87	1	R22	13K7
88	1	R28	9K53
89	4	R29, R35, R79, R92	20K
90	1	R32	100R
91	1	R36	40K2
92	10	R37, R38, R42, R46, R47, R48, R50, R51, R52, R86	1M-1%
93	5	R40, R41, R43, R64, R89	56K-1%
94	1	R44	470R
95	6	R45, R76, R78, R83, R87, R88	470K-1%
96	1	R49	560K-1%
97	5	R53, R54, R61, R62, R94	1K5
98	1	R56	0R
99	4	R57, R58, R59, R60	499K
100	1	R63	5K11
101	4	R65, R72, R77, R81	1K
102	1	R66	NTC 10R SCK20100
103	2	R67, R90	33R
104	1	R68	QAR-R015-3W
105	2	R69, R70	180K
106	1	R71	7K5
107	2	R75, R91	2R2
108	2	R84, R93	47K
109	2	TMC1, TMC2	TMC_PSL480713
110	11	TOR1, TOR2, TOR3, TOR5, TOR6, TOR7, TOR8, TOR9, TOR10, TOR11, TOR12	FIX3_7
111	1	TP1	T POINT R
112	2	TR1, TR2	10K
113	1	TSW1	X
114	1	TSW2	M74015-ELY1510 or YT-59802-1
115	1	T1	TSWITCH53
116	1	T2	T8-GDRV
117	1	U1	TC4420COA
118	1	U2	ICE3PCS01G
119	1	U3	TNY266PN
120	1	U4	UC3845AD8
121	1	U5	LM311DT
122	1	U6	LM393DT
123	6	XQ1, XD1, XQ2, XD2, XQ3, XD3	X

KPSL5012R01A

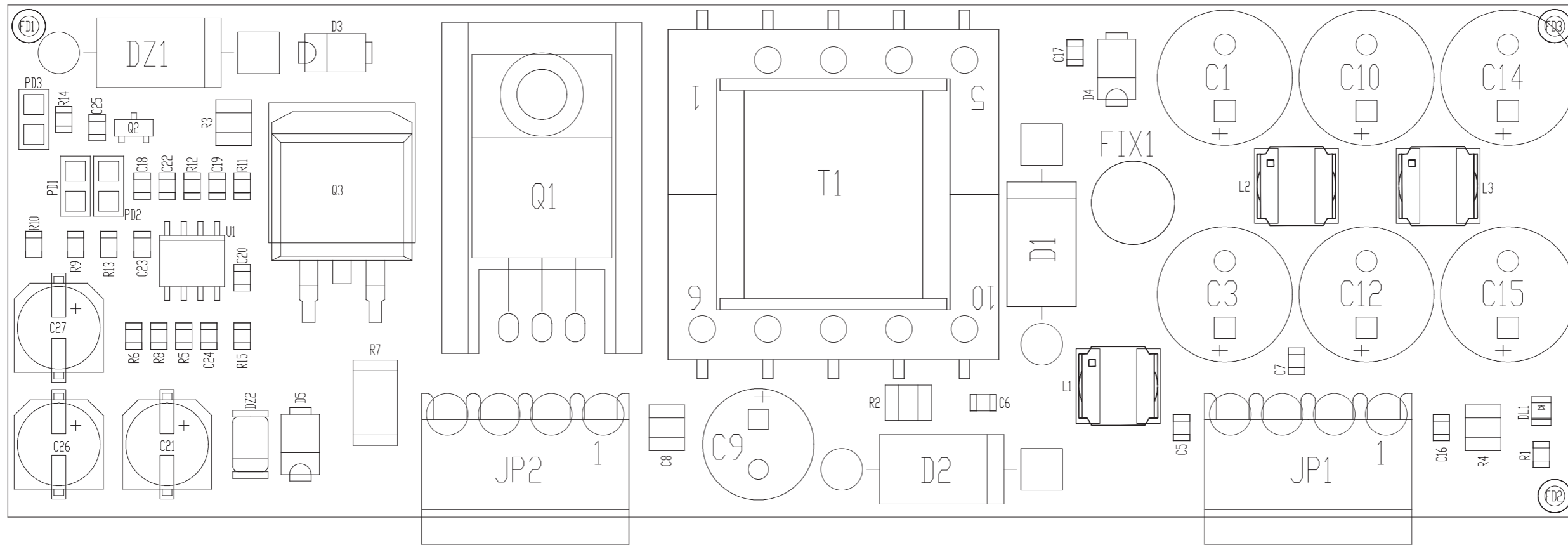

PRODUCT NAME : TEX300LCD

DESIGNER : UT

PART NAME : POWER SUPPLY 50V PFC (AUX SECTION)

DATE : 18/07/18 REVISION : 1.0 SCALE : 2:1 SIZE : A4 PAGE : 1 DI 1

ARCHIVING : "RVUT" SERVER, "RILASCIATI" FOLDER

PROJECT CODE : <>

DOCUMENT CODE : KPSL5012R01A_AUS



KPSL5012R01A

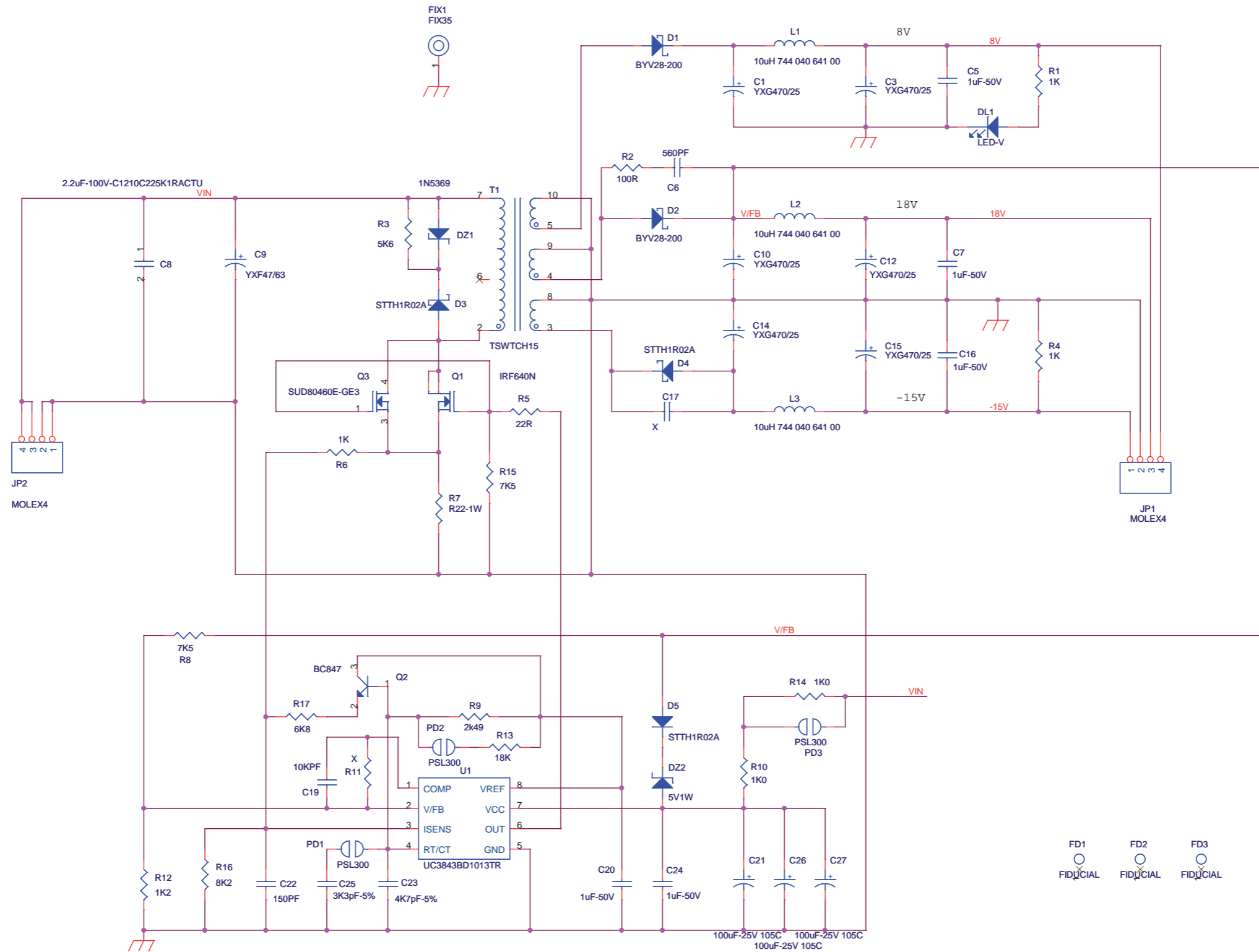

Description: POWER SUPPLY 50V PFC (AUX SECTION)		
Designer: UT	Size: A3	Page: 1 of 1
Part No.: KPSL5012R01A_AUS	Rev.: 1.0	Date: 18/07/2018



KPSL5012R01A

POWER SUPPLY 50V PFC (AUX SECTION) Revised: 18/07/2018

KPSL5012R01A_AUS Revision: 1.0

UT

Item	Quantity	Reference	Part
1	6	C1, C3, C10, C12, C14, C15	YXG470/25
2	5	C5, C7, C16, C20, C24	1uF-50V
3	1	C6	560PF
4	1	C8	2.2uF-100V-C1210C225K1RACTU
5	1	C9	YXF47/63
6	2	R11, C17	X
7	1	C19	10KPF
8	3	C21, C26, C27	100uF-25V 105C
9	1	C22	150PF
10	1	C23	4K7pF-5%
11	1	C25	3K3pF-5%
12	1	DL1	LED-V
13	1	DZ1	1N5369
14	1	DZ2	5V1W
15	2	D1, D2	BYV28-200
16	3	D3, D4, D5	STTH1R02A
17	3	FD1, FD2, FD3	FIDUCIAL
18	1	FIX1	FIX35
19	2	JP1, JP2	MOLEX4
20	3	L1, L2, L3	10uH 744 040 641 00
21	3	PD1, PD2, PD3	PSL300
22	1	Q1	IRF640N
23	1	Q2	BC847
24	1	Q3	SUD80460E-GE3
25	2	R1, R6	1K
26	1	R2	100R
27	1	R3	5K6
28	1	R4	1K
29	1	R5	22R
30	1	R7	R22-1W
31	2	R8, R15	7K5
32	1	R9	2k49
33	2	R10, R14	1K0
34	1	R12	1K2
35	1	R13	18K
36	1	R16	8K2
37	1	R17	6K8
38	1	T1	TSWTCH15
39	1	U1	UC3843BD1013TR

SLTL0509R01V01

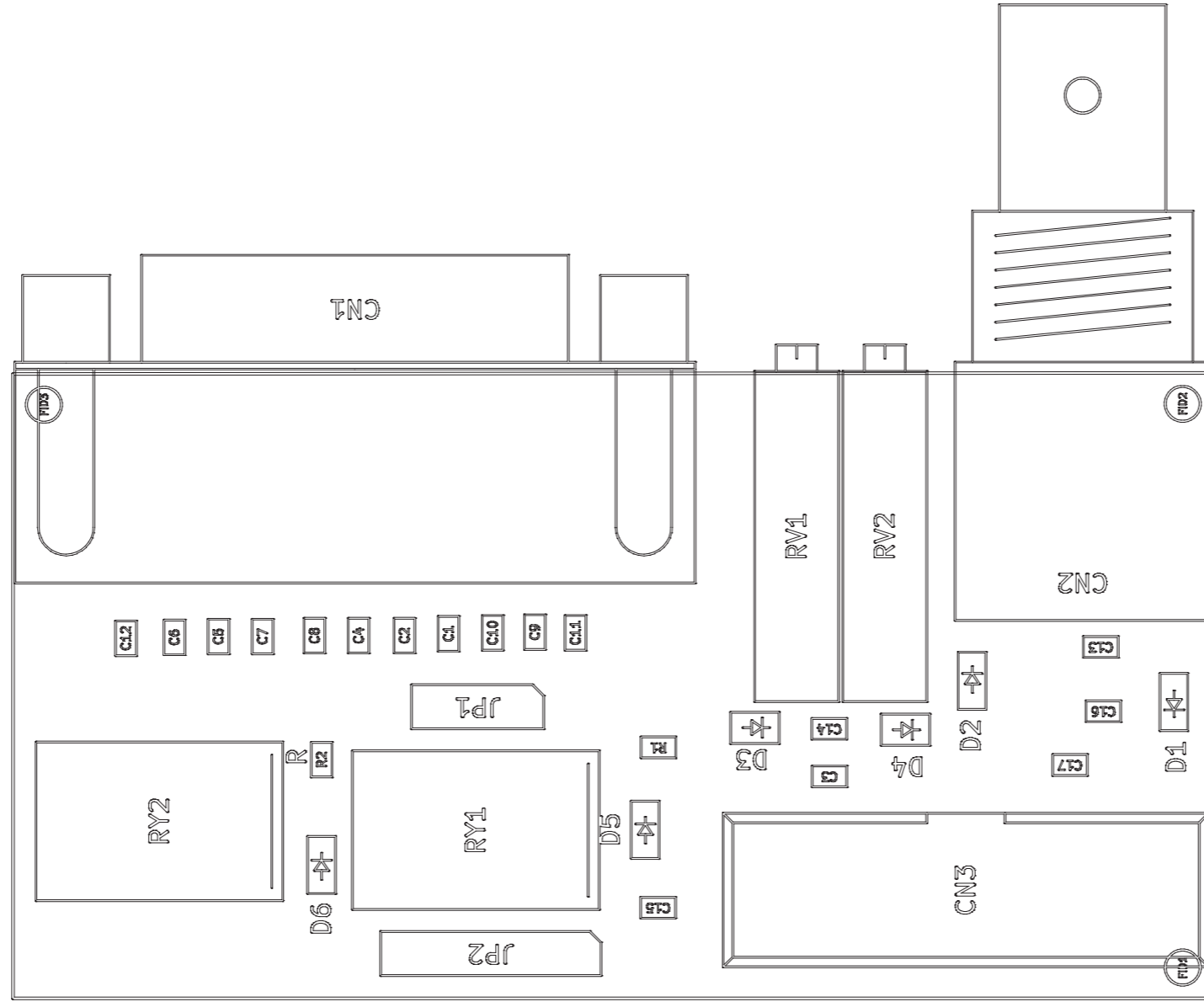

PRODUCT NAME : TEX-TFT

DESIGNER : FRANCESCHI A.

ARCHIVING : 'RVRUT' SERVER, 'RILASCIATI' FOLDER

PART NAME : TELEMETRY CARD

DATE : 22/06/20 | REVISION : 1.0 | SCALE : 2:1 | SIZE : A4 | PAGE : 1 DI 1

PROJECT CODE : <> | DOCUMENT CODE : SLTL0509R01V**

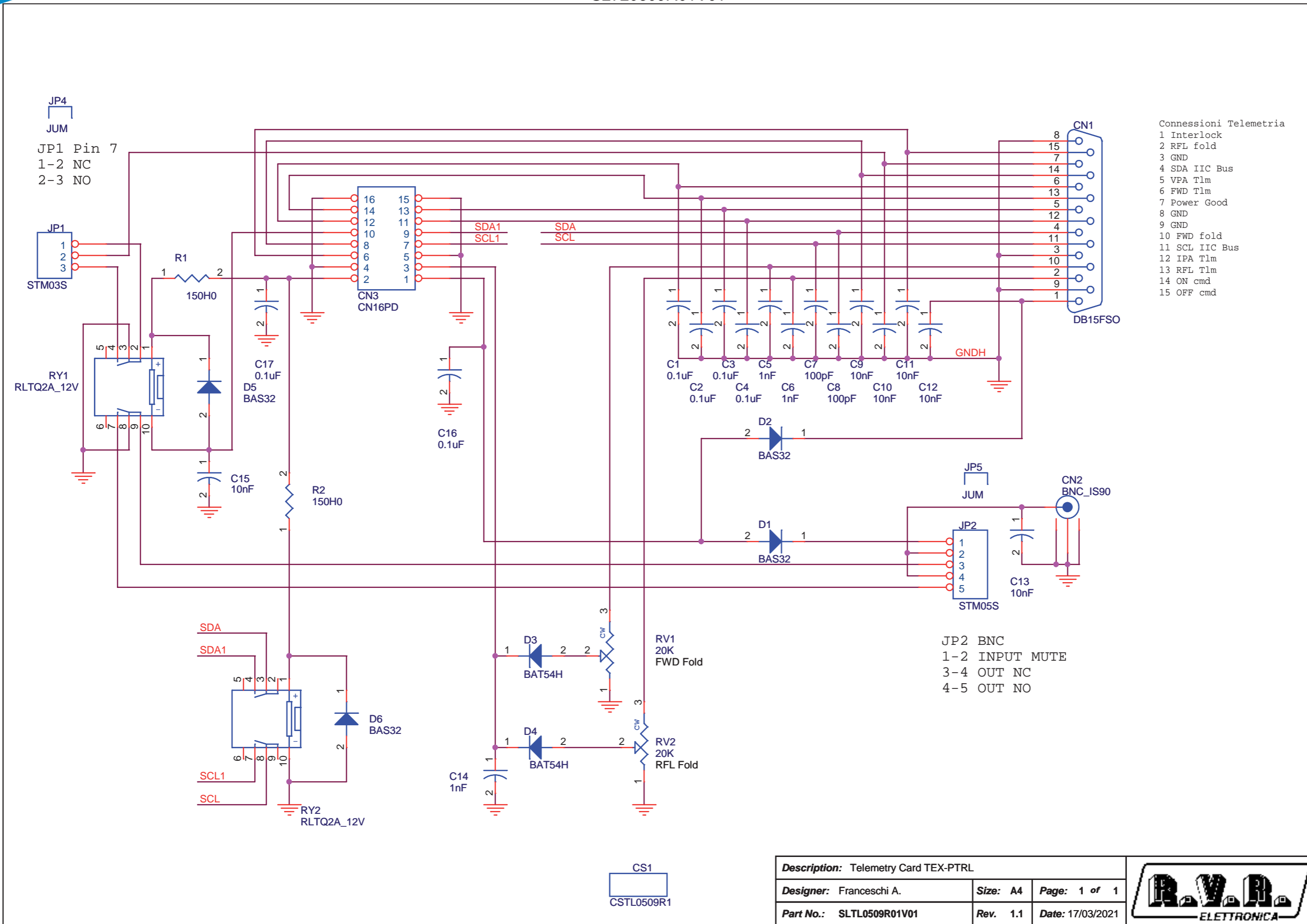

SLTL0509R01V01

Telemetry Card TEX-PTRL Revised: 17/03/2021
 SLTL0509R01V01 Revision: 1.1
 Franceschi A.

Item	Quantity	Reference	Part	Description
1	1	CN1	DB15FSO	DB15 fem. PCB 90° conn.
2	1	CN2	BNC_IS90	Metal BNC conn. 90°
3	1	CN3	CN16PD	16 way pcb conn. with holder
4	1	CS1	CSTL0509R1	Printed Circuit board
5	6	C1, C2, C3, C4, C16, C17	0.1uF	0805 SMD capacitor
6	3	C5, C6, C14	1nF	0805 SMD capacitor
7	2	C7, C8	100pF	0805 SMD capacitor
8	6	C9, C10, C11, C12, C13, C15	10nF	0805 SMD capacitor
9	4	D1, D2, D5, D6	BAS32	MINIMELF SMD Diode
10	2	D3, D4	BAT54H	SOD123F SMD Diode
11	1	JP1	STM03S	Male strip 3 pin
12	1	JP2	STM05S	Male strip 5 pin
13	2	JP4, JP5	JUM	Jumper
14	2	RV1, RV2	20K	Trimmer Rg H 3006
15	2	RY1, RY2	RLTQ2A_12V	TQ2 relay
16	2	R1, R2	150H0	0805 SMD res.

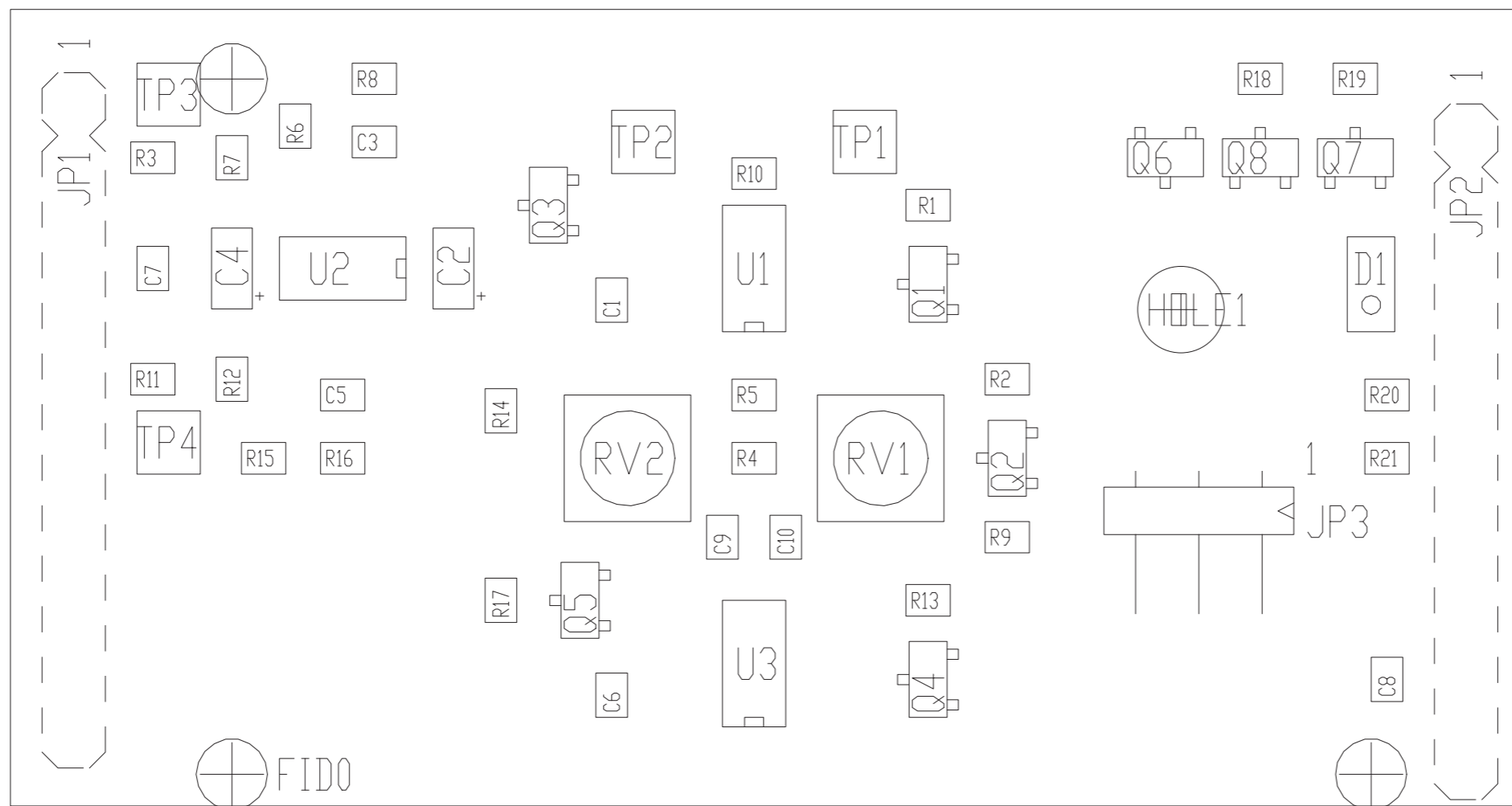

PRODUCT NAME : TEX-TFT

PART NAME : L/R Clipper for Stereo Coder

DESIGNER : FRANCESCHI A.

REVISION : 1.0 SCALE : 1:1 SIZE : A4 PAGE : 1 DI 1

ARCHIVING : "RVRUT" SERVER, "RILASCIATI" FOLDER

PROJECT CODE : 252 DOCUMENT CODE : SLCS0391R01V**



SLCS0391R01V02

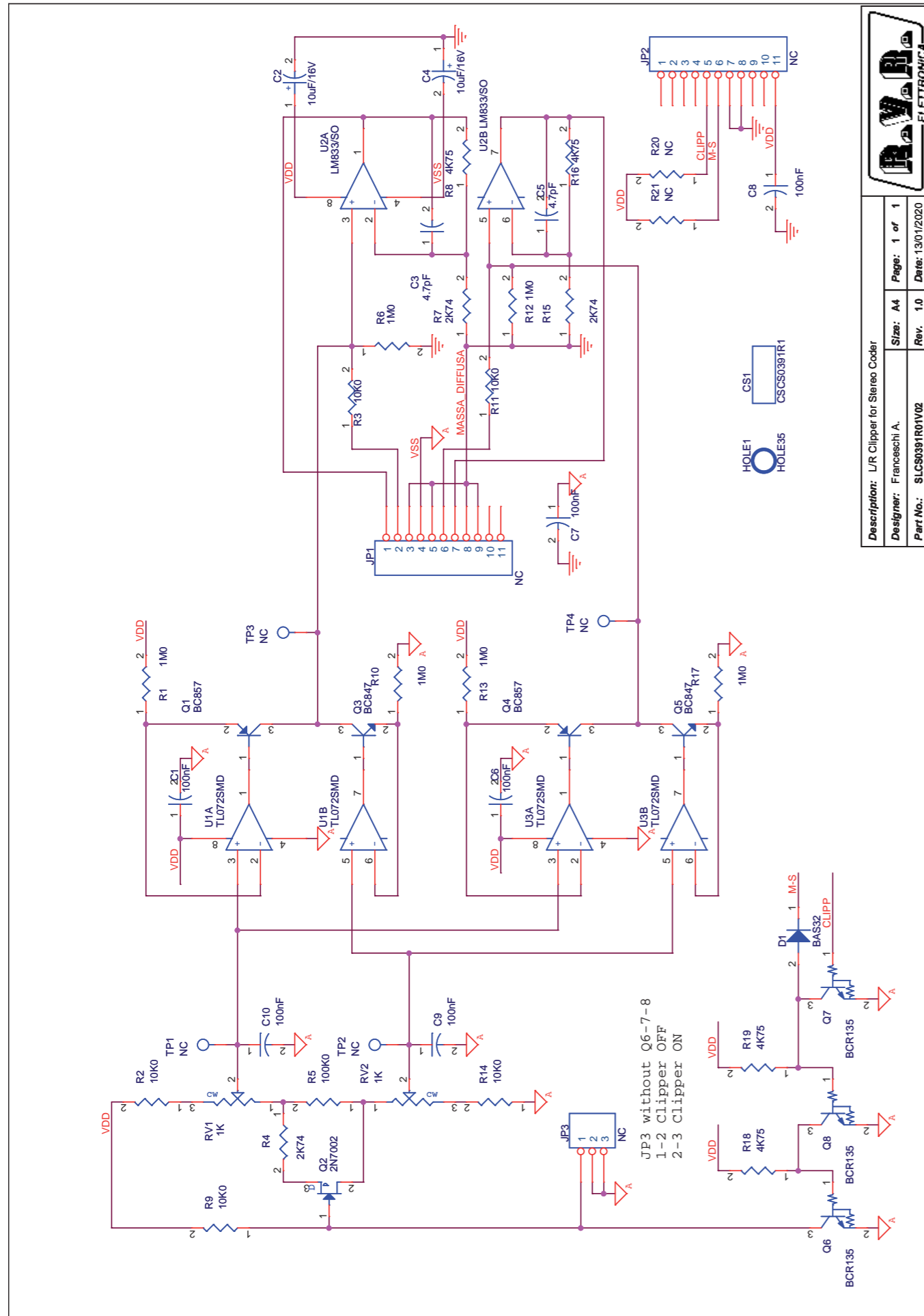

Description: L/R Clipper for Stereo Coder
Designer: Franceschi A.
Part No.: SLCS0391R01V02
Size: A4
Page: 1 of 1
Rev.: 1.0
Date: 13/01/2020

L/R Clipper for Stereo Coder Revised: Monday, Jan 13, 2020
 SLCS0391R01V02 Revision: 1.0
 Franceschi A.

Item	Quantity	Reference	Part	Description
1	1	CS1	CSCS0391R1	Circuito stampato
2	6	C1,C6,C7,C8,C9,C10	100nF	Cond. SMD 0805
3	2	C2,C4	10uF/16V	Cond. Elett. SMD tant. size A
4	2	C3,C5	4.7pF	Cond. SMD 0805
5	1	D1	BAS32	MINIMELF SMD Diode
6	1	HOLE1	HOLE35	Foro da 3.5mm
7	2	JP1,JP2	NC	Strip maschio 11 pin
8	1	JP3	NC	Strip maschio 3 pin a 90°
9	2	Q1,Q4	BC857	Trans. PNP SOT23
10	1	Q2	2N7002	Trans. FET SOT23
11	2	Q3,Q5	BC847	Trans. NPN SOT23
12	3	Q6,Q7,Q8	BCR135	Trans./Res. NPN SOT23
13	2	RV1,RV2	1K	Trimmer SMD
14	6	R1,R6,R10,R12,R13,R17	1M0	Res. SMD 0805
15	5	R2,R3,R9,R11,R14	10K0	Res. SMD 0805
16	3	R4,R7,R15	2K74	Res. SMD 0805
17	1	R5	100K0	Res. SMD 0805
18	4	R8,R16,R18,R19	4K75	Res. SMD 0805
19	2	R20,R21	NC	Res. SMD 0805
20	4	TP1,TP2,TP3,TP4	NC	Test point
21	2	U1,U3	TL072SMD	Dual Op. SMD SO8
22	1	U2	LM833/SO	Dual Op. SMD SO8

SLAU0469R01V04

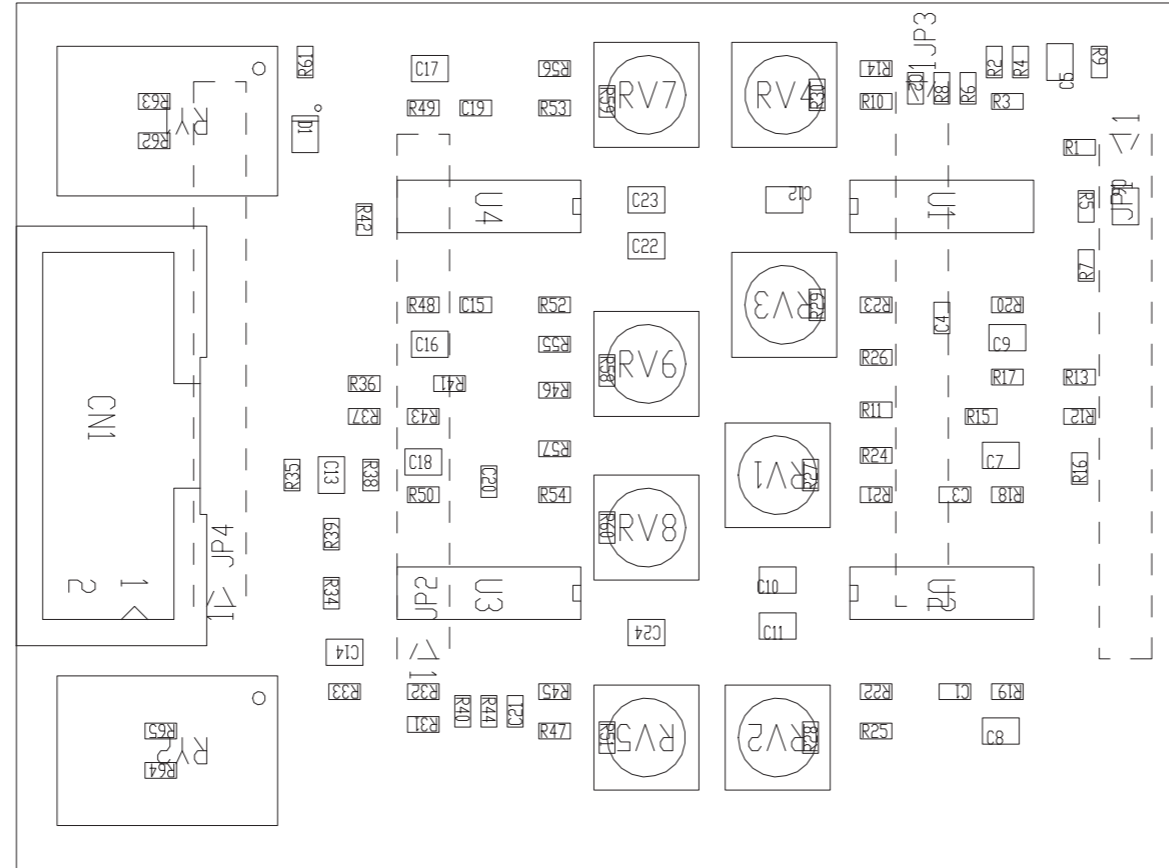

PRODUCT NAME : TEX-LCD

DESIGNER : FRANCESCHI A.

ARCHIVING : "RVRUT" SERVER, "RILASCIATI" FOLDER

PART NAME : AUDID FILTER 15KHZ

DATE : 03/05/17

REVISION : 1.0

SCALE : 2:1

SIZE : A4

PAGE : 1

DI 1

DOCUMENT CODE : SLAU0469R01V**

PROJECT CODE : 057

SLAU0469R01V04

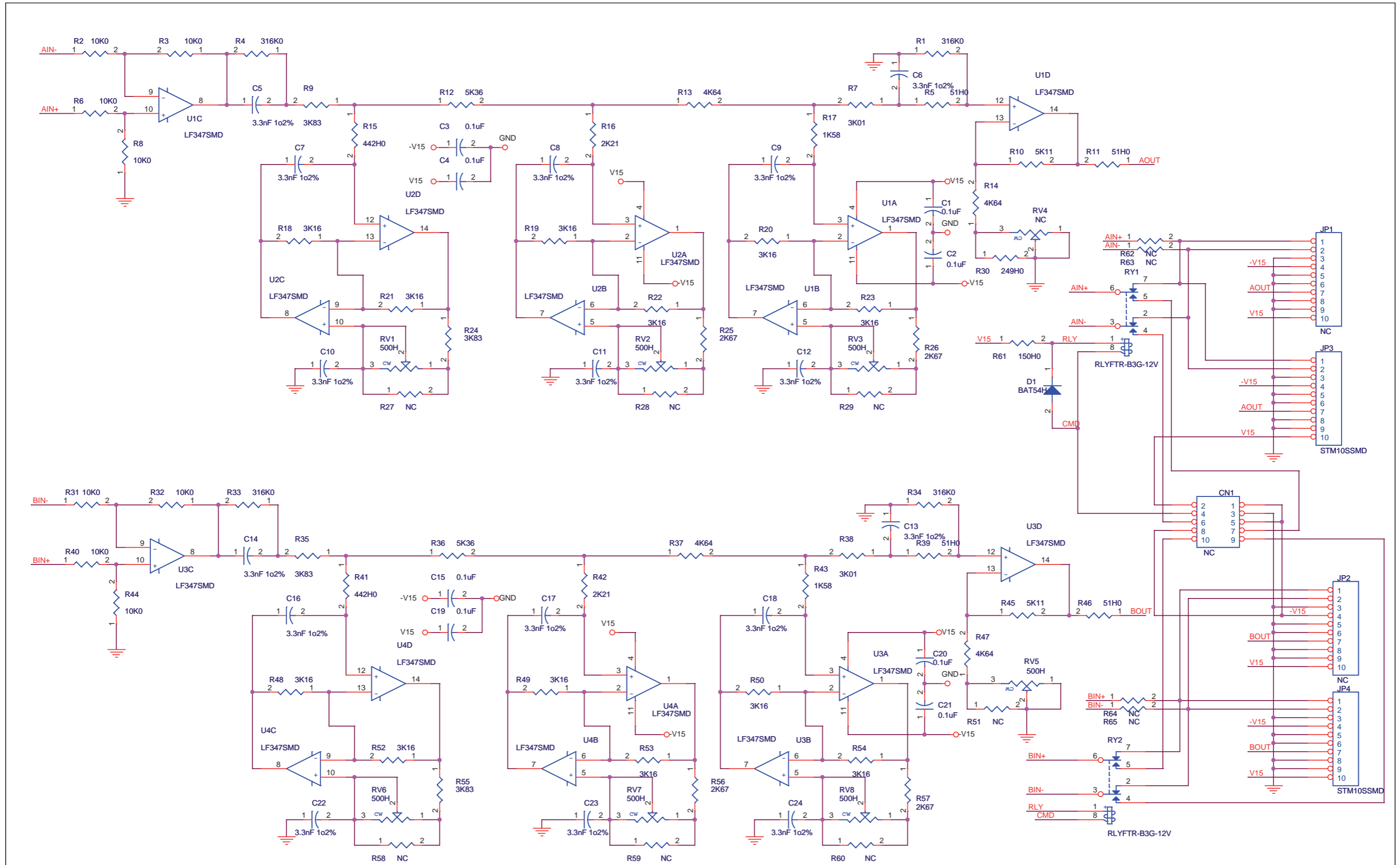

CS1
CSAU0469R1

Description: Audio Filter 15Khz TFT w AES-EBU			
Designer: Franceschi A.	Size: A3	Page: 1 of 1	
Part No.: SLAU0469R01V04	Rev. 1.0	Date: 03/04/2018	

SLAU0469R01V04

Audio Filter 15Khz TFT w AES-EBU Revised: 03/04/2018
 SLAU0469R01V04 Revision: 1.0
 Franceschi A.

Item	Quantity	Reference	Part	Description
1	1	CN1	NC	Conn. 10 poli Flat cs
2	1	CS1	CSAU0469R1	Circuito stampato
3	8	C1, C2, C3, C4, C15, C19, C20, C21	0.1uF	Cond. SMD 0603
4	16	C5, C6, C7, C8, C9, C10, C11, C12, C13, C14, C16, C17, C18, C22, C23, C24	3.3nF 1o2%	Cond. SMD 0805 COG
5	1	D1	BAT54H	SOD323 SMD Diode
6	2	JP1, JP2	NC	Male strip 10 pin SMD
7	2	JP3, JP4	STM10SSMD	Male strip 10 pin SMD
8	7	RV1, RV2, RV3, RV5, RV6, RV7, RV8	500H	Trimmer SMD V 3314
9	1	RV4	NC	Trimmer SMD V 3314
10	2	RY1, RY2	RLYFTR-B3G-12V	Rele' FTR-B3G
11	4	R1, R4, R33, R34	316K0	Res. SMD 0603
12	8	R2, R3, R6, R8, R31, R32, R40, R44	10K0	Res. SMD 0603
13	4	R5, R11, R39, R46	51H0	Res. SMD 0603
14	2	R7, R38	3K01	Res. SMD 0603
15	4	R9, R24, R35, R55	3K83	Res. SMD 0603
16	2	R10, R45	5K11	Res. SMD 0603
17	2	R12, R36	5K36	Res. SMD 0603
18	4	R13, R14, R37, R47	4K64	Res. SMD 0603
19	2	R15, R41	442H0	Res. SMD 0603
20	2	R16, R42	2K21	Res. SMD 0603
21	2	R17, R43	1K58	Res. SMD 0603
22	12	R18, R19, R20, R21, R22, R23, R48, R49, R50, R52, R53, R54	3K16	Res. SMD 0603
23	4	R25, R26, R56, R57	2K67	Res. SMD 0603
24	11	R27, R28, R29, R51, R58, R59, R60, R62, R63, R64, R65	NC	Res. SMD 0603
25	1	R30	249H0	Res. SMD 0603
26	1	R61	150H0	Res. SMD 0603
27	4	U1, U2, U3, U4	LF347SMD	Quad Op. SMD SO14