

HC3 LCD

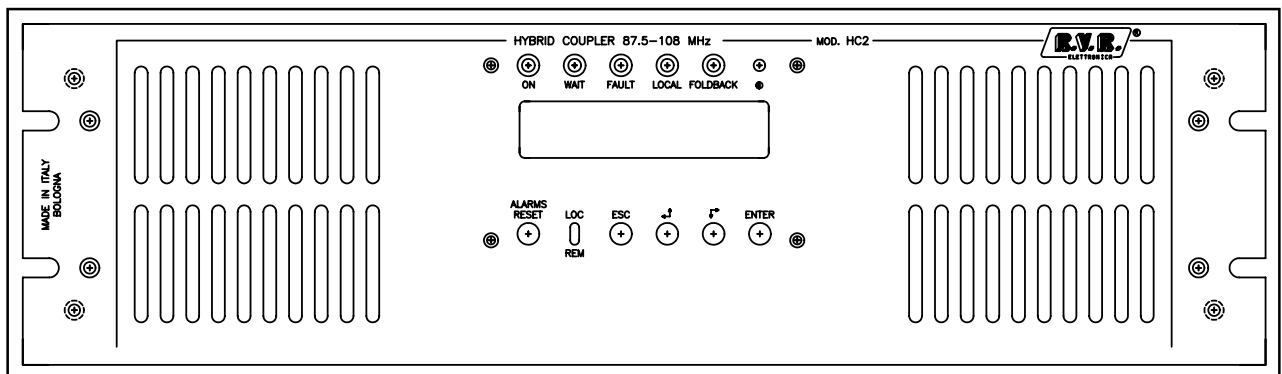

User Manual Volume 1

Manufactured by



Italy



File name: HC3LCD10_EN.P65

Version: 1.0

Date: 11/02/2002

Revision History

Version	Date	Reason	Editor
1.0	11/02/2002	New version	D. Canazza

HC3 - User Manual
Version 1.0

© Copyright 2002
R.V.R. Elettronica SpA
Via del Fonditore 2/2c - 40138 - Bologna (Italia)
Telefono: +39 051 6010506
Fax: +39 051 6011104
Email: info@rvr.it
Web: www.rvr.it

All rights reserved

Printed and bound in Italy. No part of this manual may be reproduced, memorized or transmitted in any form or by any means, electronic or mechanic, including photocopying, recording or by any information storage and retrieval system, without written permission of the copyright owner.

Table of Content

1. Preliminary instructions	1
2. Warranty	3
3. First Aid	5
3.1 Treatment of electrical shocks	5
3.2 Treatment of electrical Burns	6
4. General Description	7
5. Installation and Use	9
5.1 Preparation	9
5.2 Operation	9
5.3 Software	10
5.3.1 RF Power switch menu (Fnc)	12
5.3.2 Power menu (Pwr)	12
5.3.3 Power Amplifier menu (P.A.)	13
5.3.4 Threshold setting menu	13
5.3.5 Alarms menu	14
5.3.6 Various menu	15
5.3.7 Version menu	16
5.3.8 Protection system	16
6. Controls, Indicators and Connectors	19
6.1 Front Panel	19
6.2 Rear Panel	20
7. Technical Specifications	21
7.1 Dimensional and Environmental Specifications	21
7.2 Electrical Specifications	21
8. Electrical description	23
8.1 Power supply	25
8.2 Power Splitter	25
8.2 System Compensation	25
8.3 Power Combiner	26
8.4 Remote Card	27
8.5 CPU	27
8.6 Telemetry connector	27
8.9 External telemetry card (optional)	28
Appendix:	
Component layouts, schematics, bills of material	

This page was intentionally left blank

1. Preliminary instructions

This manual is written as a general guide for those having previous knowledge and experience with this kind of equipment.

It is not intended to contain a complete statement of all safety rules which should be observed by personnel in using this or other electronic equipment.

The installation, use and maintenance of this piece of equipment involve risks both for the personnel performing them and for the device itself, that shall be used only by trained personnel.

R.V.R. doesn't assume responsibility for injury or damage resulting from improper procedures or practices by untrained/unqualified personnel in the handling of this unit.

Please observe all local codes and fire protection standards in the operations of this unit.



WARNING: always disconnect power before opening covers or removing any part of this unit.

Use appropriate grounding procedures to short out capacitors and high voltage points before servicing.



WARNING: This is a "CLASS A" equipment. In a residential place this equipment can cause hash. In this case can be requested to user to take the necessary measures.

R.V.R. Elettronica SpA reserves the right to modify the design and/or the technical specifications of the product and this manual without notice.

Pagina lasciata intenzionalmente in bianco
This page was intentionally left blank

2. Warranty

Any product of **R.V.R. Elettronica** is covered by a 12 (twelve) month warranty.

For components like tubes for power amplifiers, the original manufacturer's warranty applies.

R.V.R. extends to the original end-user purchaser all original manufacturers warranties which are transferable and all claims are to be made directly to R.V.R. per indicated procedures.

R.V.R.'s warranty shall not include:

- 1) Re-shipment of the unit to R.V.R. for repair purposes
- 2) Any unauthorized repair/modification
- 3) Incidental/consequential damages as a result of any defect
- 4) Nominal non-incidentals defects
- 5) Re-shipment costs or insurance of the unit or replacement units/parts

Warranty shall come into force from invoice date and for the period of the manufacturer's warranty.

Any damage to the goods must be reported to the carrier in writing on the shipment receipt.

Any discrepancy or damage discovered subsequent to delivery, shall be reported to R.V.R. within five (5) days from its receipt.

To claim your rights under this warranty:

- a. Contact the dealer or distributor where you purchased the unit. Describe the problem and ask if he has an easy solution. Dealers and Distributors are supplied with all the information about problems that may occur and usually they can repair the unit quicker than what the manufacturer could do. Very often installing errors are discovered by dealers.
- b. If your dealer cannot help you, contact R.V.R. in Bologna and explain the problem. If it is decided to return the unit to the factory, R.V.R. will mail you a regular authorization with all the necessary instructions to send back the goods.
- c. When you receive the authorization, you can return the unit. Pack it carefully for the shipment, preferably using the original packing and seal the package perfectly. The customer always assumes the risks of loss (i.e., R.V.R. is never responsible for damage or loss), until the package reaches R.V.R. premises. For this reason, we suggest you to insure the goods for the whole value. Shipment must be effected C.I.F. (PREPAID) to the address specified by R.V.R.'s service manager on the authorization.



DO NOT RETURN UNITS WITHOUT OUR AUTHORIZATION AS THEY WILL BE REFUSED.

- a Be sure to enclose a written technical report where mention all the problems found and a copy of your original invoice establishing the starting date of the warranty.

Replacement and warranty parts may be order from the following address. Be sure to include the equipment model and serial number as well as part description and part number.

R.V.R. Elettronica SpA
Via del Fonditore, 2/2c
40138 BOLOGNA
ITALY
Tel. +39 051 6010506

3. First Aid

The personnel employed in the installation, use and maintenance of the device, shall be familiar with theory and practice of first aid.

3.1 Treatment of electrical shocks

3.1.1 If victim is not responsive

follow the A-B-C's of basic life support

- Place victim flat on his back on a hard surface.
- Open airway: lift up neck, push forehead back
- clear out mouth if necessary and observe for breathing
- if not breathing, begin artificial breathing (Figure 2): tilt head, pinch nostrils, make airtight seal, four quick full breaths. Remember mouth to mouth resuscitation must be commenced as soon as possible

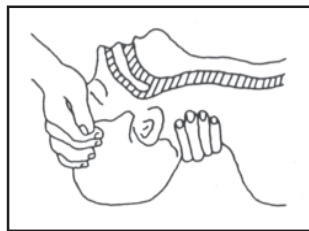

Figure 1



Figure 2

- Check carotid pulse (**Figure 3**); if pulse is absent, begin artificial circulation (**Figure 4**) depressing sternum 1 1/2" TO 2" (**Figure 5**).



Figura 3



Figura 4

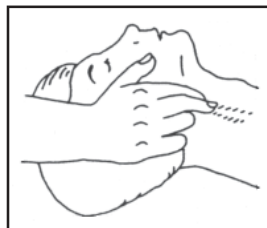

Figura 5

- APPROX. 80 SEC. : ONE RESCUER, 15 COMPRESSIONS
- APPROX. 60 SEC.: TWO RESCUERS, 5 COMPRESSIONS, 1 BREATH
- DO NOT INTERRUPT RHYTHM OF COMPRESSIONS WHEN SECOND PERSON IS GIVING BREATH
- Call for medical assistance as soon as possible.

3.1.2 If victim is responsive

- Keep them warm
- Keep them as quiet as possible
- Loosen their clothing (a reclining position is recommended)
- Call for medical help as soon as possible

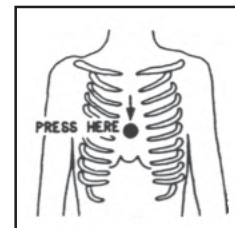
3.2 Treatment of electrical Burns

3.2.1 Extensive burned and broken skin

- Cover area with clean sheet or cloth (Cleansed available cloth article).
- Do not break blisters, remove tissue, remove adhered particles of clothing, or apply any salve or ointment.
- Treat victim for shock as required.
- Arrange transportation to a hospital as quickly as possible.
- If arms or legs are affected keep them elevated

If medical help will not be available within an hour and the victim is conscious and not vomiting, give him a weak solution of salt and soda: 1 level teaspoonful of salt and 1/2 level teaspoonful of baking soda to each quart of water (neither hot or cold). Allow victim to sip slowly about 4 ounces (half a glass) over a period of 15 minutes. Discontinue fluid if vomiting occurs



Do not give alcohol

3.2.2 Less severe burns (1st and 2nd degree)

- Apply cool (not ice cold) compresses using the cleansed available cloth article.
- Do not break blisters, remove tissue, remove adhered particles of clothing, or apply salve or ointment.
- Apply clean dry dressing if necessary.
- Treat victim for shock as required.
- Arrange transportation to a hospital as quickly as possible
- If arms or legs are affected keep them elevated.

4. General Description

The HC3, produced by R.V.R. Elettronica, is a hybrid coupler at 3 way realized in "Strip-Lines" technology. Its function is to split into three portions the RF signal coming from a RF exciter, adjusting the relative phases, to pass them through three external RF power amplifiers and then to combine the output of the amplifiers into a single RF amplified signal to be forwarded to the antenna output.

The HC3 is produced in the version for five transmitters of 1 kW max output power everyone (total 3 kW).

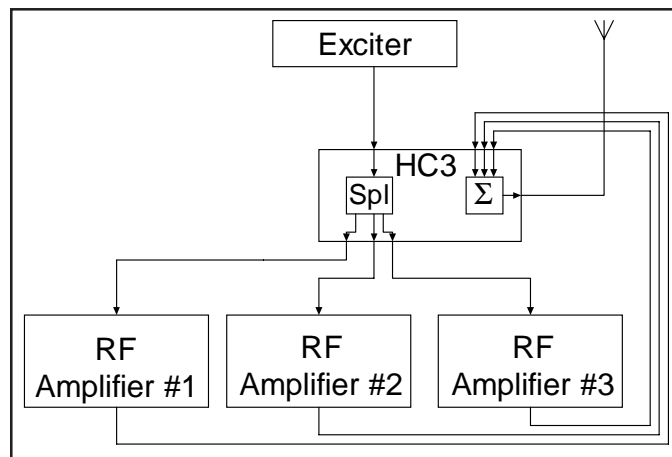

The nominal working principle of a FM transmitter based on a hybrid coupler scheme like HC3, foresees that the used amplifiers shall produce the same RF power that will be added with the same phase. Possible differences in the power level or phase of the amplifiers generate the so-called *unbalancement power* that is in part dissipated inside the coupler. The HC3 guarantees the overall working of the transmitter even if one of the amplifiers is completely off-service. In such case, approximately 1 kW of the power generated by the surviving amplifier is routed to the antenna anyway; the other part of the delivered power (that is unbalancement power) is dissipated inside the combiner.

The HC5 is controlled by a microcontroller system, that includes a LCD display and a series of keys for the interaction with the user, that realizes the following functions:

- Measurement and visualization of the coupler's working parameters
- Activation and deactivation of the power output of the system
- Protection of the coupler with respect to potentially dangerous situations like exceeding emitted or unbalancement power, overdrive or overtemperature
- Detection of user-settable attention thresholds (e.g. output power being below a certain value), that are made externally available as digital states on the "telemetry" connector
- Communications with external devices

The management software of the HC3 is based on a menu system. The user can navigate through the menu system using four buttons, ESC, move LEFT/UP, move RIGHT/DOWN and ENTER. A fifth button is used to reset the alarm counters, if any alarm has been triggered before.

Five LEDs on the front panel of the amplifier show the current status of the machine: ON/OFF, WAIT, FAULT, LOCAL and FOLDBACK

A switch on the front panel allows to select the LOCAL or REMOTE working mode:

- LOCAL mode allows to control the machine using the buttons on the front panel, while remote control (that is using the telemetry connector) is disabled;
- In REMOTE mode, remote control is enabled, while the buttons on the front panel can be used only to read parameters and not to change them

The LOCAL working mode is signalled by a yellow LED on the front panel being lit.

The different working parameters are made available for the remote control applications on the telemetry connector, as voltage levels that are proportional to the value of the parameter under consideration. Digital output signals related to alarms or warnings are also present on the connector, together with the digital input like ON/OFF switching or alarms reset.

The hybrid coupler includes an input for optional external 24 V dc power supply. This power source will automatically be used to supply the CPU section in case the mains power goes off. In this way, it is possible to interact (locally or remotely) with the device even in absence of mains supply.

The HC3 can be connected to the exciter of the transmitter using a “interlock” cable, so that it is possible for it to deactivate RF power emission in case of malfunctioning of the transmitting system. An analogous effect can be reached also in case the exciter misses the interlock functionality, connecting the mains supply of the exciter to the auxiliary mains plug of the HC3 “AUX OUT AC LINE”. This plug is in fact opened using a relay under the same conditions that cause the activation of the interlock.

5. Installation and use

This chapter is intended to summarize the necessary points for the installation of the device. In case any of the arguments is unclear, for example when you use the combiner for the first time, we suggest to carefully read the whole manual.

5.1 Preparation

Unpack the HC3 and before any other operation check the unit for any shipping damage; in particular, check that all the controls and connectors on the front and rear panels are in good conditions.

If it is necessary, check the integrity and the value of the fuse inside the voltage changer block; the required fuse type is:

- 1Aux 4A 5X20 Mains 4A 6X30 (220-240V)
- 1Aux 4A 5X20 Mains 4A 6X30 (100-120V)

Connect the RF output cable of the exciter to the N-type input of the splitting section of the combiner. Connect three cables between the output N connectors of the splitting section of the combiner and the RF input of three suitable amplifiers. Connect three cables between the RF output of the amplifiers and the input connectors of the combining section of the coupler.

Connect the output connector of the combining section to the antenna feeder or to a dummy load with a power rating suitable for your application. Link, using a coaxial cable, the BNC "Alarms/Interlock" connector to the "Interlock" connector of the exciter. Connect the "Feed back" connector to the "EXT AGC" input of the exciter, if such a functionality is present (described in the documentation of the transmitting station).

The hybrid coupler shall be mounted in one rack that contain a anti-strap device to not expose accidentally the mains conductors.



ATTENTION: It is essential that the unit is properly earthed to ensure both the safety of operation as well as the correct working of the equipment.

5.2 Operation

To perform its intended purpose, the HC3 is always used in a transmitter comprising an exciter and three RF amplifiers. In the following description, we will in general refer to these external devices.

As soon as the HC3 is supplied, verify that the ON LED is lit. The LCD display shows a presentation screen, and after a few seconds it will pass to the default screen, showing the values of the forward and reflected power.

Switch the exciter on (at its minimum power level) and wait for it to lock on the working frequency. When the PLL has locked, progressively increase its output

power, while controlling the displays of the exciter, of the amplifiers and of the hybrid coupler. Keep increasing the exciter output overall output of the combiner reaches the desired value, that is at most the nominal power rating of the transmitting station.

At this point, it is possible for the user to verify all the working parameters of the amplifier using the management software.

Normally, the device doesn't require any human supervision for its normal operation. If any alarm condition arise, these are automatically managed by the embedded protection system, and notified to the user with the LEDs on the panel or via messages on the LCD display.

5.3 Software

This chapter describes the way the microprocessor system controls the hybrid coupler, and how the user can interact with it.

Note that the user can give commands to the device only when it's set in LOCAL mode using the switch on the front panel. Otherwise, the user will only be allowed to read the parameters, but not to change any of them.

The management of the HC3 is performed by a generic software used in different classes of equipment produced by R.V.R. Elettronica SpA, like the HC combiners or the RF amplifiers PJ500M-C and PJ1000M.

For this reason, some options that are related to other kinds of devices are deactivated in the software version that is installed in the HC3 (see for example the P.A. menu).

Note that some of the parameters that are measured and can be read may be, in some circumstances, not available. This situation mostly arises when, for physical reasons, the measured values are not significant to be used in the control software.

When the value for a parameter is not available for such reasons, it's substituted with the symbol "==".

Figure 5.1 shows the complete flow diagram of the management software of the coupler, that can be basically seen as build up of a default screen, plus a series of submenus.

At power on, the LCD display will show the following presentation screen, indicating the name of the device:



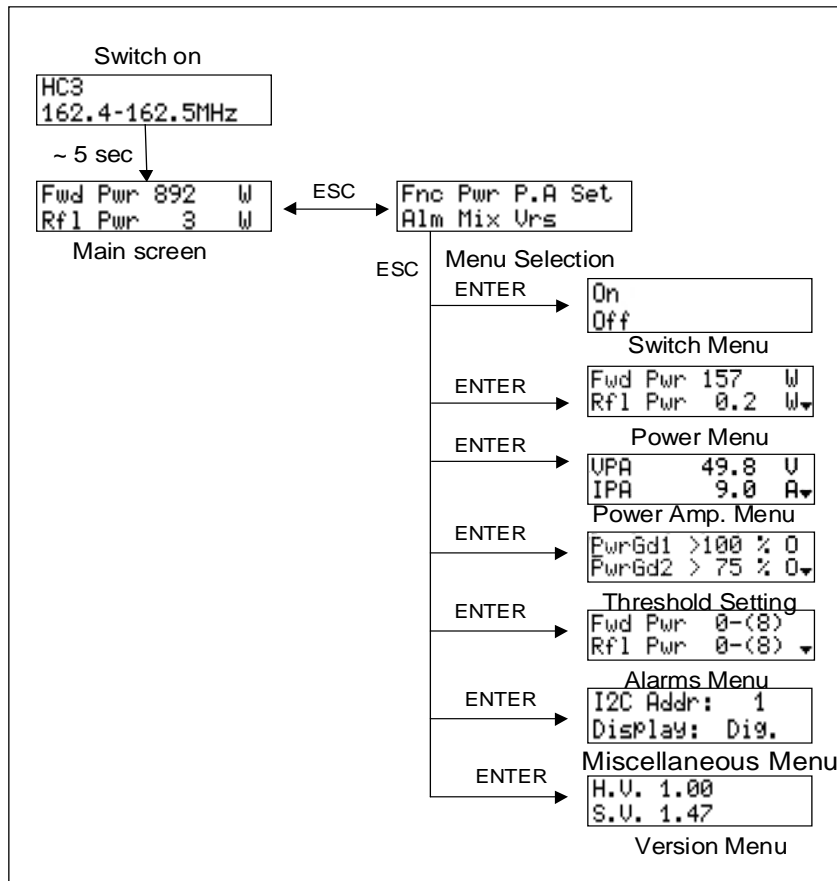

After a few seconds, the main screen will be displayed, reporting the values of Forward power and Reflected power:

```

Fwd Pwr 892 W
Rfl Pwr 3 W
  
```

The management software will remain indefinitely in this default screen, until the user pushes the ESC button.

Pushing the ESC button, the user will be presented with the menu selection screen, from which the other screens can be accessed:

```

Fnc Pwr P.A Set
Alm Mix Urs
  
```

Pushing again the ESC button, the software goes back to the default screen.

To enter into one of the submenus, just select the corresponding name (that will be indicated by a flashing underscore) with the LEFT and RIGHT buttons, and then push ENTER.

5.3.1 RF Power switch menu (Fnc)

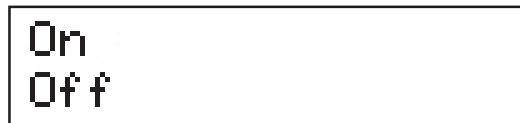

From this menu, the user can “switch” ON and OFF the hybrid coupler.

The result of this command is that when the HC3 is put in OFF mode, the inner conductor of the “Alarm” connector is shorted to ground, so that the exciter is put in stand-by mode (this will happen only if provided with an interlock connector, and if correctly connected with the hybrid coupler). At the same time, the auxiliary mains output is opened, so that if an exciter is connected to it, it will be shut off.

When the hybrid coupler is switched OFF, the software waits a few minutes to permit the proper cooling of the device, and then sends a signal to the relays of the blowers to turn them off too.

Each two hours, while the machine is OFF, the software enables the blowers for a while to dissipate the heat generated by the circuitry and to avoid possible malfunctions of the blowers due to long inactivity periods.

Switching ON again the hybrid coupler, the interlock circuit is opened, reenabling the power emission in the connected exciter, the auxiliary mains plug supply is powered and the blowers are restarted.

5.3.2 Power menu (Pwr)

This multi-line scrollable menu allows the user to read all the measurements related to the behaviour of the power section of the combiner:

- Forward Power (Fwd Pwr)
- Reflected Power (Rfl Pwr)
- Standing Wave Ratio (SWR) (Not active)
- Input Power (Inp Pwr) (Not active)
- Rejected PWR (Rej PWR)

Depending on the configuration of the machine, some of the measures could be deactivated.

The complete aspect of the screen is the following figure (please note that only two lines at a time are visible, use the UP and DOWN buttons to scroll):

Fwd Pwr	892	W
Rfl Pwr	3	W
SWR	Off	
InP Pwr	Off	
Rej SWR	15	W

5.3.3 Power Amplifier menu (P.A.)

This multi-line scrollable menu reports to the user some internal measurement of the device:

- Voltage (VPA) - Not active
- Current (IPA) - Not active
- Efficiency - Not active
- Temperature
- Mains voltage (Mains - percentage variation with respect to the nominal voltage)

The complete aspect of the screen is the following figure (please note that only two lines at a time are visible, use the UP and DOWN buttons to scroll):

VPA	Off	V
IPA	Off	A
Eff.	Off	%
Temp.	22.8	C
Mains	5	%

5.3.4 Threshold setting menu

As described in the introduction, the amplifier offers a maximum of four user settable alarms. For each of them, one of the working parameters is compared against a threshold value that can be modified by the user. The results of the comparisons are available on the telemetry connector or as dry contacts on the optional external telemetry board, and can be read on the display as "O" (open, i.e. the result is false) or "C" (closed, i.e. the result is true).

Two of the settable thresholds are related to the RF emitted power (**Power Good**), while the third is connected to the amount of reflected power (**Reflected Warning**).

The thresholds are expressed as percentage of full-scale value of the relevant quantity.

The full scale values for the HC5 are the following:

- Forward Power 3000W
- Reflect Power 300W

To change the values of the thresholds, execute the following procedure:

- Select the line to modify (UP and DOWN buttons)
- Push the ENTER button
- Modify the value of the threshold (UP and DOWN buttons)
- Push the ENTER button to confirm

The following figure shows an example of configuration for this menu.

```

PwrGd1 > 80 % 0
PwrGd2 > 50 % 0
Rf1War > 70 % 0
    
```

In this example, the thresholds of the warnings are:

- PwrGd 1 2400W (80% X 3000W)
- PwrGd2 1500W (50% X 3000W)
- Rf1War 210W (70% X 300W)

5.3.5 Alarms menu

This screen gives to the user information regarding the status of the protection system included in the hybrid coupler.

It is constituted by a certain number of lines, each containing the name of a variable controlled by the system and the kind of intervention that is undertaken by the system in case the parameter surpasses its limit.

The latter can be of the kind: **X - (Y)**, **Wait**, or **Dis.** (Disabled).

The aspect of this multi-line screen is the following (only two lines at a time are visible, use the UP and DOWN buttons to scroll):

Fwd Pwr	0-(8)
Rfl Pwr	0-(8)
Inp Pwr	0-(8)
U.P.A.	Dis.
I.P.A.	Dis.
Temp.	Wait
Rej SWR	0-(8)
Mains	Wait
SWR	Dis.
Eff.	Dis.

The function of this menu is essentially a help for the technician to identify the causes of possible malfunctions of the transmitter.

5.3.6 Various menu

Two operations can be performed using this menu:

- Setup the address of the I²C serial bus type connection
- Setup the kind of visualitation in the default menu

```
I2C Addr: 1
Display: Dig.
```

The default address of I²C communication is relevant when the coupler is connected with other RVR' devices that use this protocol. We raccomand not to change this parameter if not necessary.

The visualitation mode can be **Digital** (the default mode described in chapter 5.3) or **Analog**:

```
Rfl Pwr 6 ▾
■ ■
```

In analog mode, a little triangle indicates the reflected power level set in the threshold set menu (under RflWar), while the bar below shows the in real time level reflected power.

This last kind of visualitation is best used when the combiner output is connected to a device that has to be tuned, as a cavity.

5.3.7 Version menu

This menu shows the hardware (H.V.) and software versions (S.V.) of the machine.



5.3.8 Protection sistem

The protection system implemented in hybrid coupler is based on two types of reactions, the “Foldback” and the temporary disabling.

5.3.8.1 Foldback

The foldback circuit controls the level of a dc voltage that is available on the dedicated BNC connector (F.BACK) on the rear of the HC3.

The foldback voltage remains approximately constant until one of the amounts that are connected to the foldback doesn't surpass its nominal value (full scale). When this happens, the foldback voltage is rised proportionally to the amount the threshold is surpassed, and a yellow LED is lit on the front panel, signalling the intervention of the circuit. In figure, X represents one of the variables connected to the foldback, X_0 is the full scale of the variable, V_{FB} is the voltage present on the BNC:

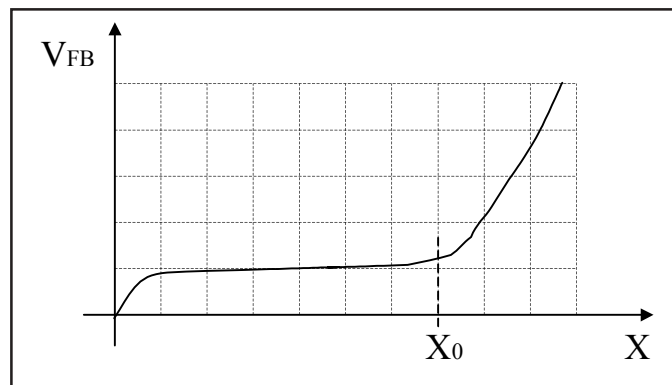

In the HC3, the variables connected to the foldback are:

- Forward power
- Reflected power
- Rejected power
- Temperature

The foldback voltage can be used by the transmitter's exciter to reduce accordingly the driving power. For example, RVR Elettronica's PTX-LCD is designed to use an external foldback signal of this kind.

In general, the reduction of the RF power generated by the exciter will reduce the variable that caused the foldback intervention, so that a new stability point is reached.

If any reason makes it impossible to reach a new stable point, the protection system of the HC3 will react with its Shut off/Restart procedure.

5.3.8.2 Shut off/Restart

The second kind of reaction of the protection system consists in forcing the transmitter in stand-by mode when one of the monitored variables surpasses its maximum allowed value.

To put the transmitter in stand-by, the hybrid coupler disables the exciter's RF power emission using the interlock circuit, thus disabling the overall transmitter RF power.

Depending on the kind of problem that caused the failure, after the transmitter has been inhibited, it will either be reactivated after a fixed time interval, or only when the impeding condition has been solved.

In the Alarm menu, the first kind of configuration is noted by **X - (Y)**, while the second is indicated with **Wait**. The third possibility is that the configuration of the system does not implement any protection based on a certain parameter: This would be noted with **Dis.** (Disabled).

While the amplifier is temporarily shut off for an alarm, the yellow WAIT LED is lit, and the cause of the intervention of the protection system is written on the display.

When the protection intervenes for a parameter of "cyclic" kind, a counter is incremented (the value X in the alarm screen). If the value of the counter reaches the maximum admitted value (Y), the amplifier is definitively switched off, and the red LED "fault" on the front panel is lit.

The button ALARMS RESET gives the user the opportunity to interact with the protection system. Its effect is different depending on the status the amplifier is when the button is pushed:

- If the system is in stand-by, waiting for the cycle time to expire, or if it is definitively off in FAULT state, pushing the ALARMS RESET button will immediately turn the amplifier on and reset the alarm counters
- If the system is transmitting, but some alarm occurred before, so that the alarm counters are not all at "0", pushing the ALARMS RESET button will have no effect unless the button is pushed while the user is reading the Alarm menu. In this way it is made sure that the user doesn't reset possible alarms without knowing they happened

The alarm counters are reset by the system itself without the need for an external intervention after half an hour of undisturbed (i.e. without alarms) working of the hybrid coupler

Pagina lasciata intenzionalmente in bianco
This page was intentionally left blank

6. Controls, Indicators and Connectors

This chapter describes the front and rear panels of the HC3, with a brief indication of all the different components.

6.1 Front Panel

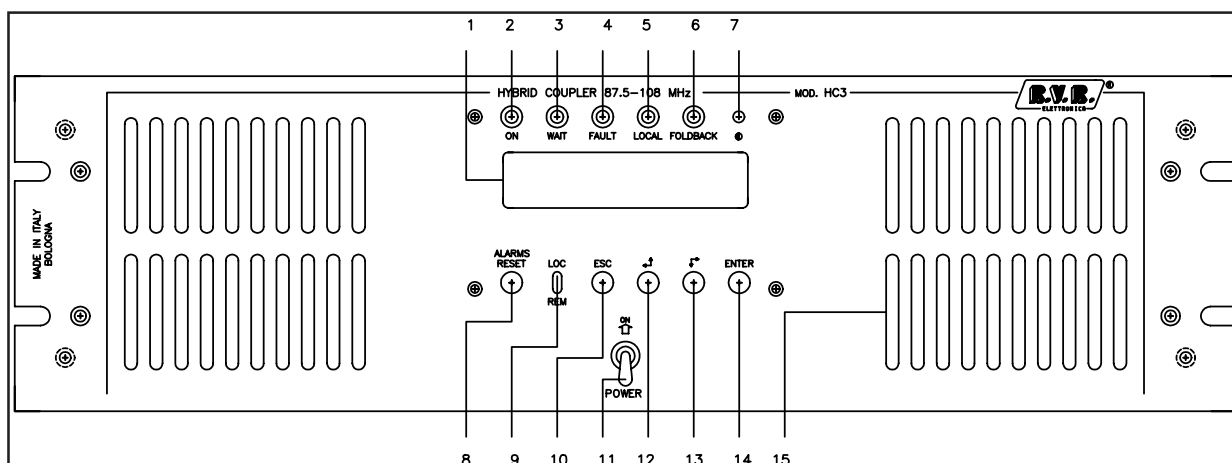

[1] DISPLAY	LCD Display.
[2] ON	Green LED, lit when the hybrid coupler is switched on.
[3] WAIT	Yellow LED indicating that the amplifier is waiting for a condition that is blocking the power output to be removed.
[4] FAULT	Red LED indicating that a fault that cannot be automatically reverted.
[5] LOCAL	Yellow LED indicating that the hybrid coupler is in local control mode.
[6] FOLDBACK	Yellow LED indicating the intervention of the foldback function (automatic reduction of the output power).
[7] BRIGHTNESS	Trimmer to regulate the brightness of the LCD display.
[8] ALARM RESET	Button used to manually reset the protection system.
[9] LOC/REM	Switch to select the local or remote control modes.
[10] ESC	Button to exit from a menu.
[11] ON/OFF	Mains switch.
[12] LEFT/UP	Button used to navigate in the menu system and to modify the changeable parameters.
[13] RIGHT/DOWN	Button used to navigate in the menu system and to modify the changeable parameters.
[14] ENTER	Button used to accept a parameter's value or to enter into a menu.
[15] AIR FILTER	Air Filter for Power Splitter and Combiner.

6.2 Rear Panel

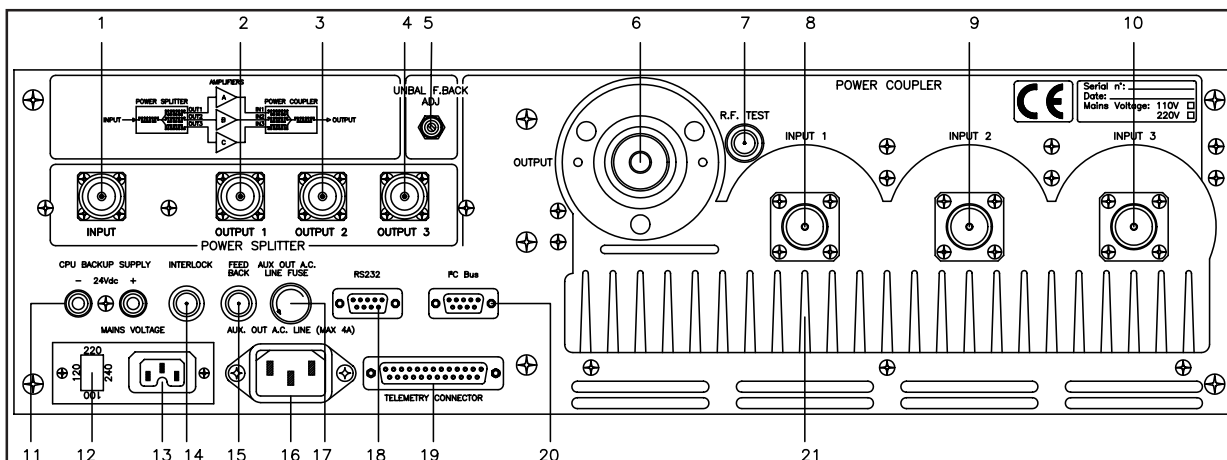

- | | |
|--|---|
| [1] INPUT | Exciter's R.F. Input connector (N-type). |
| [2] OUTPUT 1 | Power Splitter Output 1 (N-type connector) to drive Power Amplifier A. |
| [3] OUTPUT 2 | Power Splitter Output 2 (N-type connector) to drive Power Amplifier B. |
| [4] OUTPUT 3 | Power Splitter Output 3 (N-type connector) to drive Power Amplifier C. |
| [5] UNBAL F.BACK | Trimmer for Unbal Fold Back adjustment. |
| [6] OUTPUT | Power Combiner's Output (7/8" EIA Flange). |
| [7] R.F. TEST | BNC RF monitor output. The output level is -60 dB below the power output in the band 87.5-108 MHz. |
| [8] INPUT 1 | Power Combiner's Input 1 (7/8" EIA Flange) from the Power Amplifier A. |
| [9] INPUT 2 | Power Combiner's Input 2 (7/8" EIA Flange) from the Power Amplifier B. |
| [10] INPUT 3 | Power Combiner's Input 2 (7/8" EIA Flange) from the Power Amplifier C. |
| [11] 24 V | External 24 V dc power supply input for CPU backup power supply. |
| [12] VOLTAGE CHANGER &
A.C. LINE FUSE | Fuse block and Line Voltage Selector. Use a small screwdriver to change the fuse or line voltage. Rotate the block and position it for desired voltage. |
| [13] MAINS VOLT. | A.C. Power Line. |
| [14] INTERLOCK | BNC connector to inhibit an external device, as an exciter. In case of fault, the inner connector is shorted to ground. |
| [15] FEED BACK | BNC connector for the FEED BACK. |
| [16] AUX. OUT A.C.
LINE | Auxiliary Out A.C. Power Line. |
| [17] FUSE | Protection Fuse for Auxiliary Out A.C. Power Line. |
| [18] RS232 | DB9 conector to link the amplifier with external devices. |
| [19] TELEMETRY | DB25 telemetry connector. |
| [20] I ² C | DB9 connector for I ² C bus networking. |
| [21] HEAT SINK | Heat Sink. |

7. Technical Specifications

7.1 Dimensional and Environmental Specifications

Cabinet Dimensions	447.0 mm x 132.5 mm x 507.5 mm
Panel Dimensions	483 mm x 132.5 mm
Weight	17.5 Kg
Operating Temperature Range	-10 °C ÷ 50 °C
Umidity	90% Maximum, without condensation

7.2 Electrical Specifications

A.C. Power Supply	117-230 V, 50-60 Hz	
Cooling sistem	forced ventilation	
Frequency Range	87.5 MHz ÷ 108 MHz	
Max Rating Power	3.6 KW	
Power Splitter Section	Inp. Impedance	50 Ohm
	Inp. Connector	"N-type" connector
	Out. Impedance	50 Ohm
	Out. Connector	"N-type" coconnector
Power Coupler Section	Inp. Impedance	50 Ohm
	Inp. Connector	EIA 7/8" Flange
	Out. Impedance	50 Ohm
	Out. Connector	EIA 7/8" Flange

Pagina lasciata intenzionalmente in bianco
This page was intentionally left blank

8. Modules Identification

8.1 Upper view

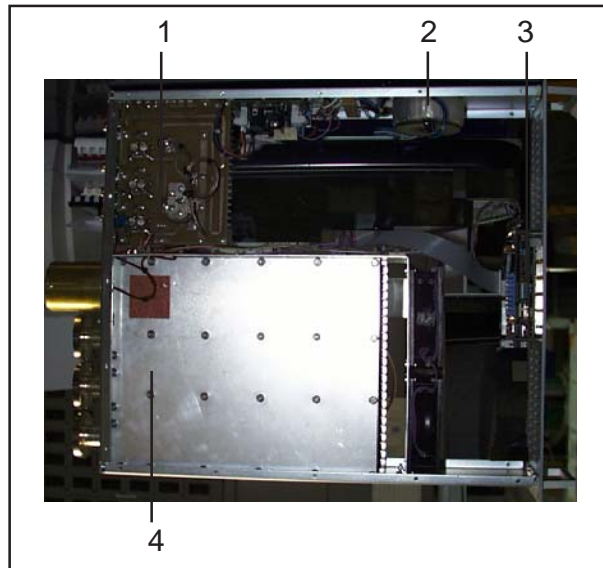

- [1] Power Splitter Board
- [2] Transformer
- [3] CPU
- [4] Power Coupler Board

8.2 Bottom view

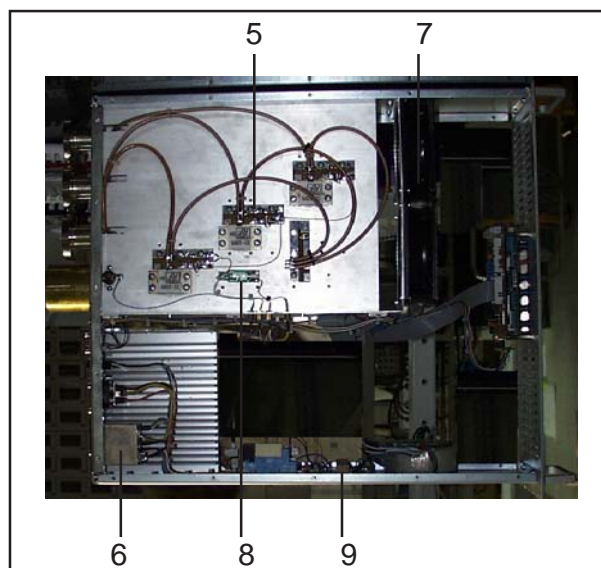

- [5] Unbal Power Card
- [6] Voltage Changer
- [7] Blowers
- [8] Temperature Sensor
- [9] Remote Card

9. Electrical Description

HC3 is composed of different modules wired between them with connectors, allowing for easy servicing or module substitution.

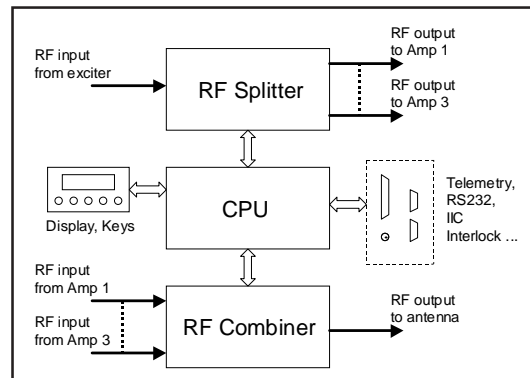

This chapter gives the information to identify, and about the function, of the single modules.

9.1 Power supply

This equipment has only a transformer (32VA) with a primary 0-100-120-220-240V and a secondary 16-0-16V, 1A to supply Alarms and CPU Card and the Remote Card.

9.2 Power Splitter

The Power Splitter circuit mounted on the rear part of the equipment on the right side, is used to split exciter's driving power to three amplifiers.

The circuit is realized with strip plus coaxial cables and three specific circuits can adjust (equalize) phases on the three outputs that are used to drive the amplifiers.

Three resistive termination placed near to the output serves to absorb any unbalanced powers in case of faulty or performance differences of some amplifier to prevent excessive power driving on the well functioning (well loaded) outputs.

The hybrid coupler is factory-adjusted so that the transmitter it is included in will work satisfyingly works over the whole FM band.

Cases may happen, that it is necessary to perform the RF adjustment of the HC5, for example if the RF interconnection cables with the amplifiers have been substituted with other of slightly different characteristics or length, or if it is desirable to optimize the transmitter's performances on a certain frequency.



WARNING: we suggest not to perform the operations described in this chapter to personnel lacking proper instrumentation and deep knowledge of the device and its working principles.

8.2 System Compensation

- 1) On the coupler instrument, select the forward power measurement mode.
- 2) Remove the coupler's upper cover.
- 3) Set the desired system working frequency on the exciter.
- 4) Set the output power of the exciter so that the system output forward power is at 80% of the nominal value.
- 5) Regulate all the variable capacitors to their middle position (Figure 9.1).

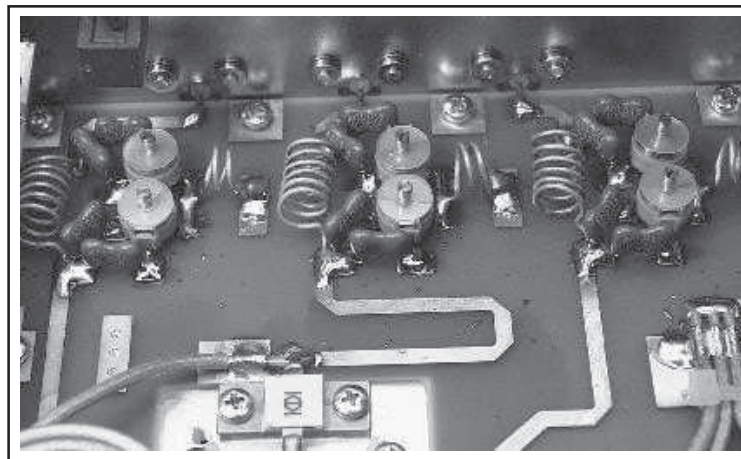

Figure 9.1

- 6) Adjust the variable capacitors (1) and (2), relative to the first amplifier output (Figure 4), to maximize the power level measured by the coupler's instrument.

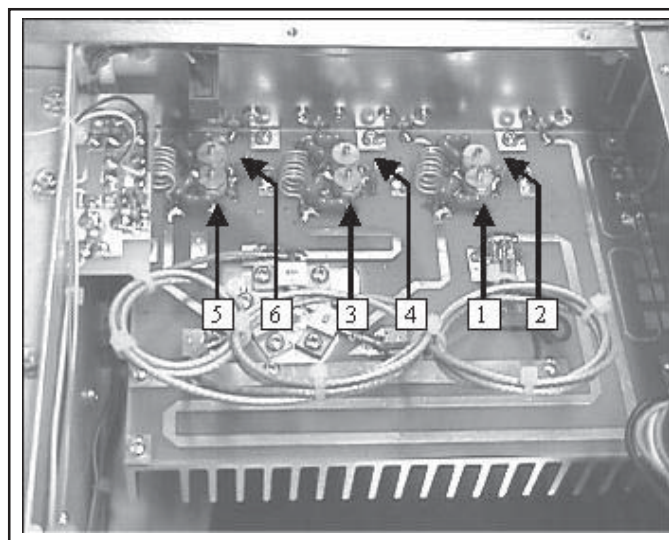

Figure 9.2

- 7) Adjust the variable capacitors (3) and (4), relative to the second amplifier output, to maximize the power level measured by the coupler's instrument.
- 8) Adjust the variable capacitors (5) and (6), relative to the third amplifier output, to maximize the power level measured by the coupler's instrument.
- 9) Repeat steps 6, 7 and 8 until the system power reaches its maximum.
- 10) Reassemble the coupler's upper cover.
- 11) Adjust the system output forward power to the nominal value.
- 12) If the compensation is done because one amplifier was replaced, it is normally necessary to operate only on the capacitors related to the substituted amplifier.

8.3 Power Combiner

The Power Combiner circuit mounted on the rear part of the equipment on the left side, is used to combine the output powers of three amplifiers.

The circuit is realized with suspended-substrate strip lines plus 50Ohm coaxial cables and guarantee equal phases on the three input power ways that are combined to obtain the antenna output power.

Three resistive terminations placed on the main cooler serve to absorb any unbalanced powers in case of faulty or performance differences of some amplifier.

8.4 Remote Card

This Card mounted on the right side of the equipment in rear position, allows to switch off the Auxiliary Out A.C. Line in case of any faulty of the equipment.

8.5 CPU

This subsystem is composed by three cards: the CPU card, the display card and the analog section card.

This subsystem implements all the software functions (measurements, protection, control, data display, communications) described in the previous chapters.

8.6 External telemetry card (optional)

This optional device is designed to interface to the telemetry connector of the HC3 LCD, and its main role is to give to the user a number of dry contacts related to the status of the amplifier. The contacts can be configured as normally open or closed, and are triggered by the four user settable thresholds plus LOC/REM, WAIT, FAULT, ON, OFF, INHIBIT.

The analog signals produced by the hybrid copupler are replicated on a DB9 connector.

This page was intentionally left blank

11. Calibration Procedures

11.1 Introduction

This chapter describes the calibration procedures that are necessary to do when you have replaced some cards or some devices, or in case of a complete replacement of the equipment into of a transmitter station.

All calibrations must be executed switching on all equipment at the minimum power.

11.2 CPU Assembly Adjustment

NOTE: This section describe the adjustment of the CPU group, in case of a substitution if it is breakdown.

- After changing the assembly, connect the amplifier as shown in the figure below.

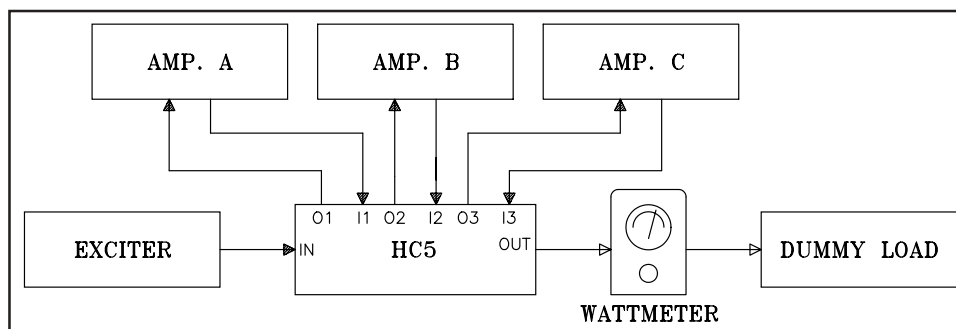

- Switch ON the HC3.

Temperature reading adjustment

- Measure the temperature of the cooling fin with a thermometer.
- Enter on the P.A. menu.
- Adjust the trimmer TR6 to read on the display the same temperature measured with the thermometer.

Mains reading adjustment

- Measure the main voltage with a multimeter.
- Enter on the P.A. menu.
- Adjust the trimmer TR8 to read on the display the value of 100% (the main voltage is visualized as percentage variation and the value 100% represents 220V).

Trimmer TR7 adjustment

- The trimmer TR7 must be turned completely counter-clockwise, to protect the input channel to the CPU.

FOLBACK intervention adjustment

- Be sure that the exciter is not operative.
- Measure the voltage on the PIN1 of JP7 on the power supply card with a multimeter, then rotate the trimmer TR9 to obtain a voltage of 0V.

Forward power reading adjustment

- Increase to 5000W at 98MHz, using as a reference the reading on the wattmeter that possibly has been connected at the end of the attenuation chain at the RF output.
- Rotate TR1 to read on the display the same value measured with the wattmeter.

Reflected power adjustment

- Apply an unbalanced load in series with a 50 Ohm load and apply in series a by-pass wattmeter BIRD.
- Increase slowly the exciter power to obtain a reflected power of 500W at 98MHz.
- Adjust TR2 to read on the display the same value measured with the wattmeter.

VPA reading adjustment

- For the hybrid combiner this reading is disabled.

IPA measurement adjustment

- For the hybrid combiner this reading is disabled.

Input power reading adjustment

- Connect to the RF input a by-pass wattmeter BIRD with a full-scale of 10 W.
- Connect a 50Ohm load to the exit and increase slowly the exciter power to obtain 5W on the instrument in series to the input.
- Rotate TR3 on the CPU assembly to read on the display the correct value measured with the wattmeter.