



# PWRMETER-D1

TECHNICAL ANNEX  
VOLUME1



## Appendix A Piani di montaggio, schemi elettrici, liste componenti / *Component layouts, schematics, bills of material*

Questa parte del manuale contiene i dettagli tecnici riguardanti la costruzione delle singole schede componenti il PWRMETER-D1. L'appendice è composta dalle seguenti sezioni:

*This part of the manual contains the technical details about the different Cards of the PWRMETER-D1. This appendix is composed of the following sections:*

Description	RVR Code	Vers.	Page
Wiring Diagrams	/	/	1
RMS RF Rectifier Card	SLMT0324R02V04	1.1	2
Wattmeter Interface Card	SL172IN1001	1.0	5
Wattmeter Protection Card	PROTF172	1.0	7

### Document History

Date	Version	Reason	Code	Editor
29/11/2013	1.0	First Release	/	J.H. Berti

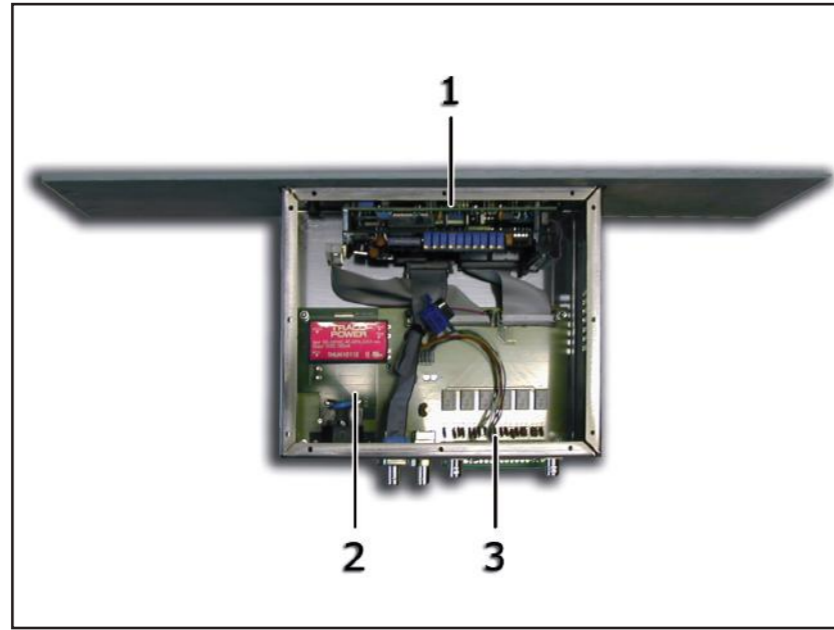

- [1] Wattmeter Protection Card
- [2] Wattmeter Interface Card
- [3] RMS RF Rectifier Card

SLMT0324R02V04

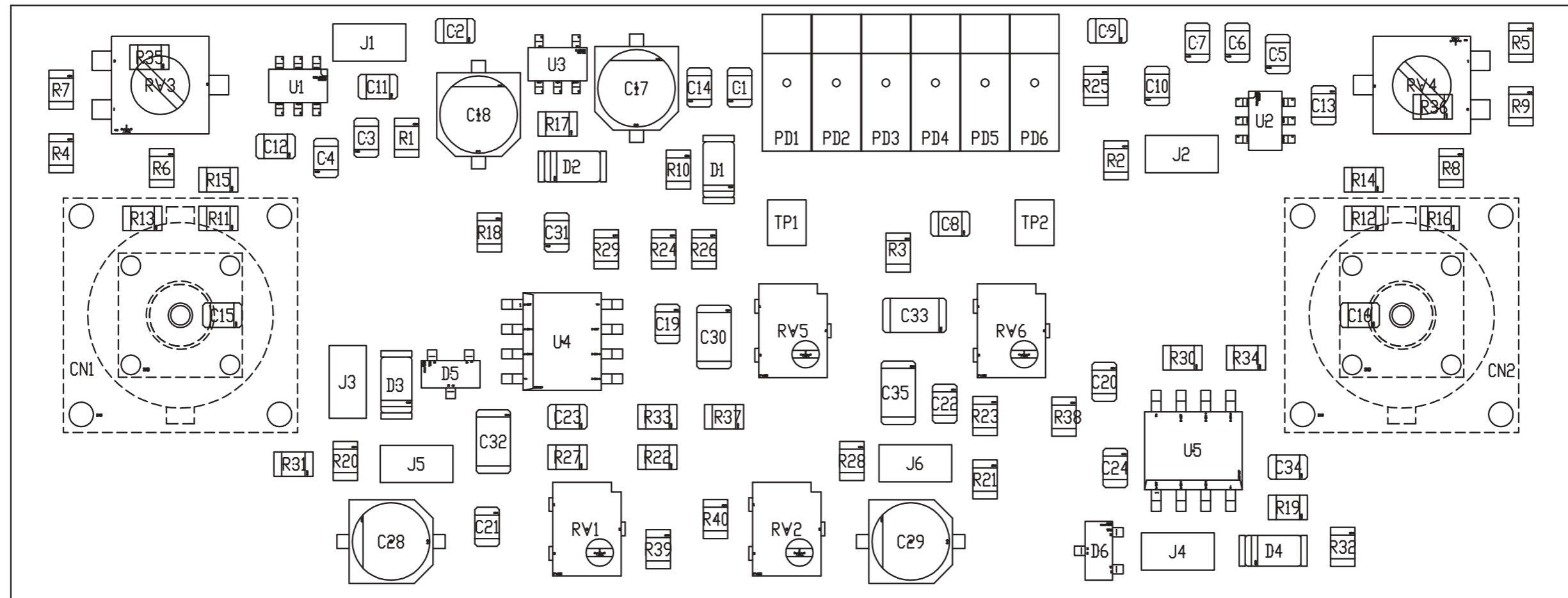

SLMT0324R02V04

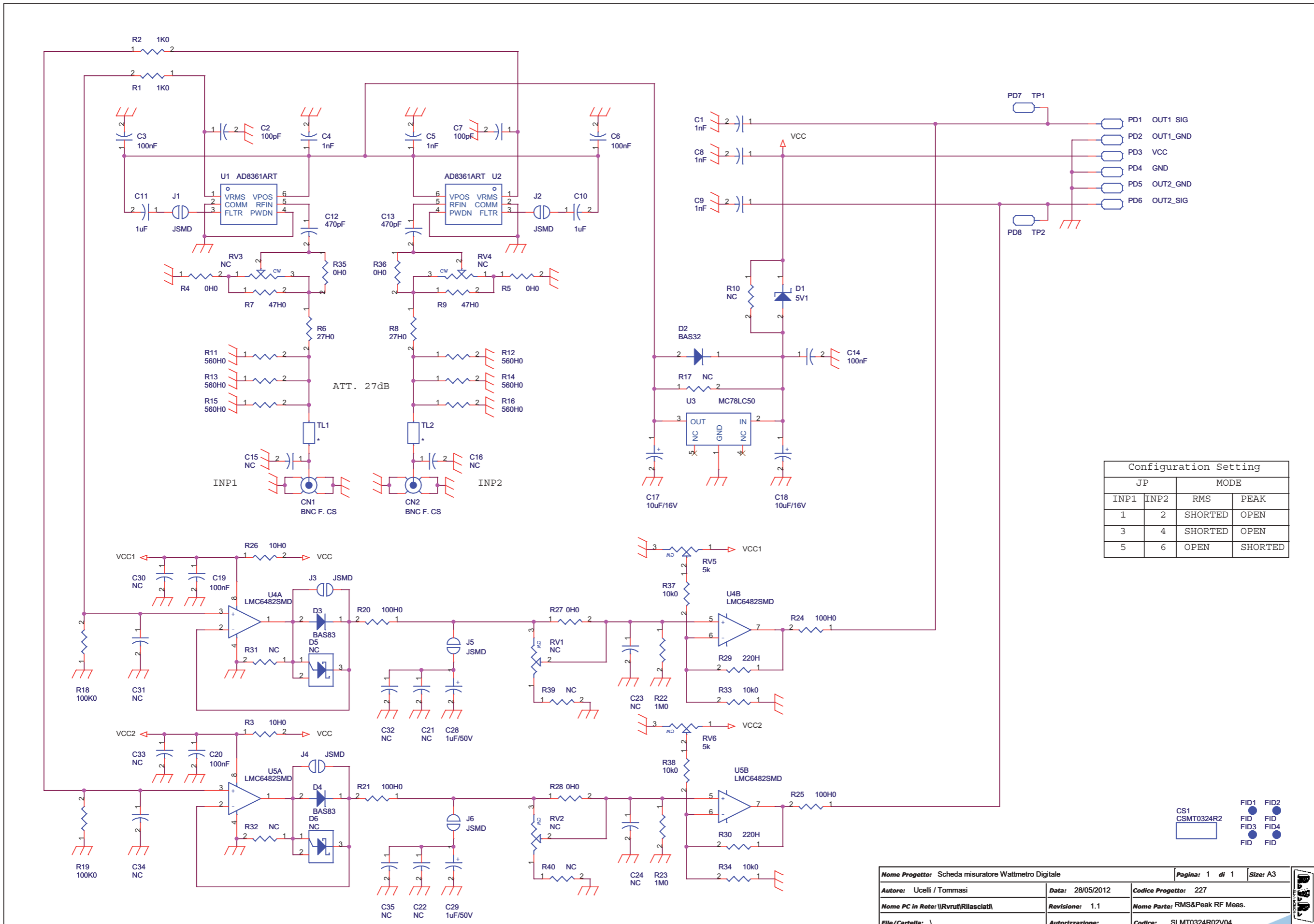

Configuration Setting			
JP		MODE	
INP1	INP2	RMS	PEAK
1	2	SHORTED	OPEN
3	4	SHORTED	OPEN
5	6	OPEN	SHORTED

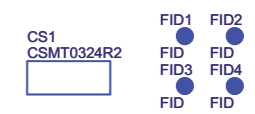

Nome Progetto: Scheda misuratore Wattmetro Digitale		Pagina: 1 di 1	Size: A3
Autore: Ucelli / Tommasi	Data: 28/05/2012	Codice Progetto: 227	
Nome PC In Rete: \\Rvru\Relasciat\	Revisione: 1.1	Nome Parte: RMS&Peak RF Meas.	
File/Cartella: \	Autorizzazione:	Codice: SLMT0324R02V04	

SLMT0324R02V04

RMS&amp;Peak RF Meas. Revised: 28/05/2012

SLMT0324R02V04 Revision: 1.1

Ucelli / Tommasi

Scheda misuratore Wattmetro Digitale

227

Item	Quantity	Reference	Part
1	2	CN1,CN2	BNC F. CS
2	1	CS1	CSMT0324R2
3	5	C1,C4,C5,C8,C9	1nF
4	2	C2,C7	100pF
5	5	C3,C6,C14,C19,C20	100nF
6	2	C10,C11	1uF
7	2	C12,C13	470pF
8	4	C15,C16,C31,C34	NC
9	2	C17,C18	10uF/16V
10	4	C21,C22,C23,C24	NC
11	2	C28,C29	1uF/50V
12	4	C30,C32,C33,C35	NC
13	1	D1	5V1
14	1	D2	BAS32
15	2	D3,D4	BAS83
16	2	D5,D6	NC
17	4	FID1,FID2,FID3,FID4	FID
18	6	J1,J2,J3,J4,J5,J6	JSMD
19	1	PD1	OUT1_SIG
20	1	PD2	OUT1_GND
21	1	PD3	VCC
22	1	PD4	GND
23	1	PD5	OUT2_GND
24	1	PD6	OUT2_SIG
25	1	PD7	TP1
26	1	PD8	TP2
27	2	RV1,RV2	NC
28	2	RV3,RV4	NC
29	2	RV5,RV6	5k
30	2	R1,R2	1K0
31	2	R3,R26	10H0
32	6	R4,R5,R27,R28,R35,R36	0H0
33	2	R6,R8	27H0
34	2	R7,R9	47H0
35	6	R10,R17,R31,R32,R39,R40	NC
36	6	R11,R12,R13,R14,R15,R16	560H0
37	2	R18,R19	100K0
38	4	R20,R21,R24,R25	100H0
39	2	R22,R23	1M0
40	2	R29,R30	220H
41	4	R33,R34,R37,R38	10K0
42	2	TL1,TL2	*
43	2	U1,U2	AD8361ART
44	1	U3	MC78LC50
45	2	U4,U5	LMC6482SMD



SL172IN1001

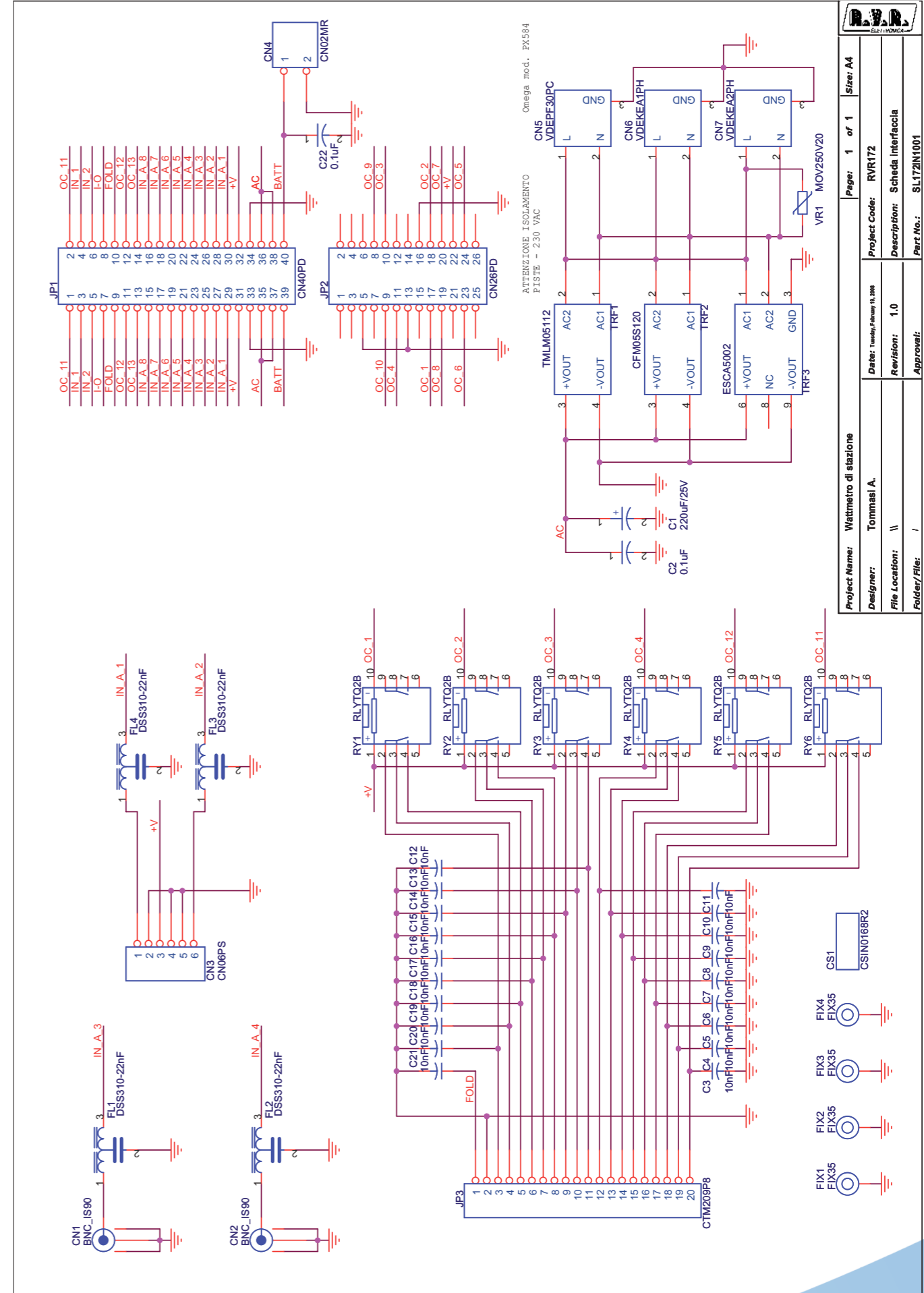
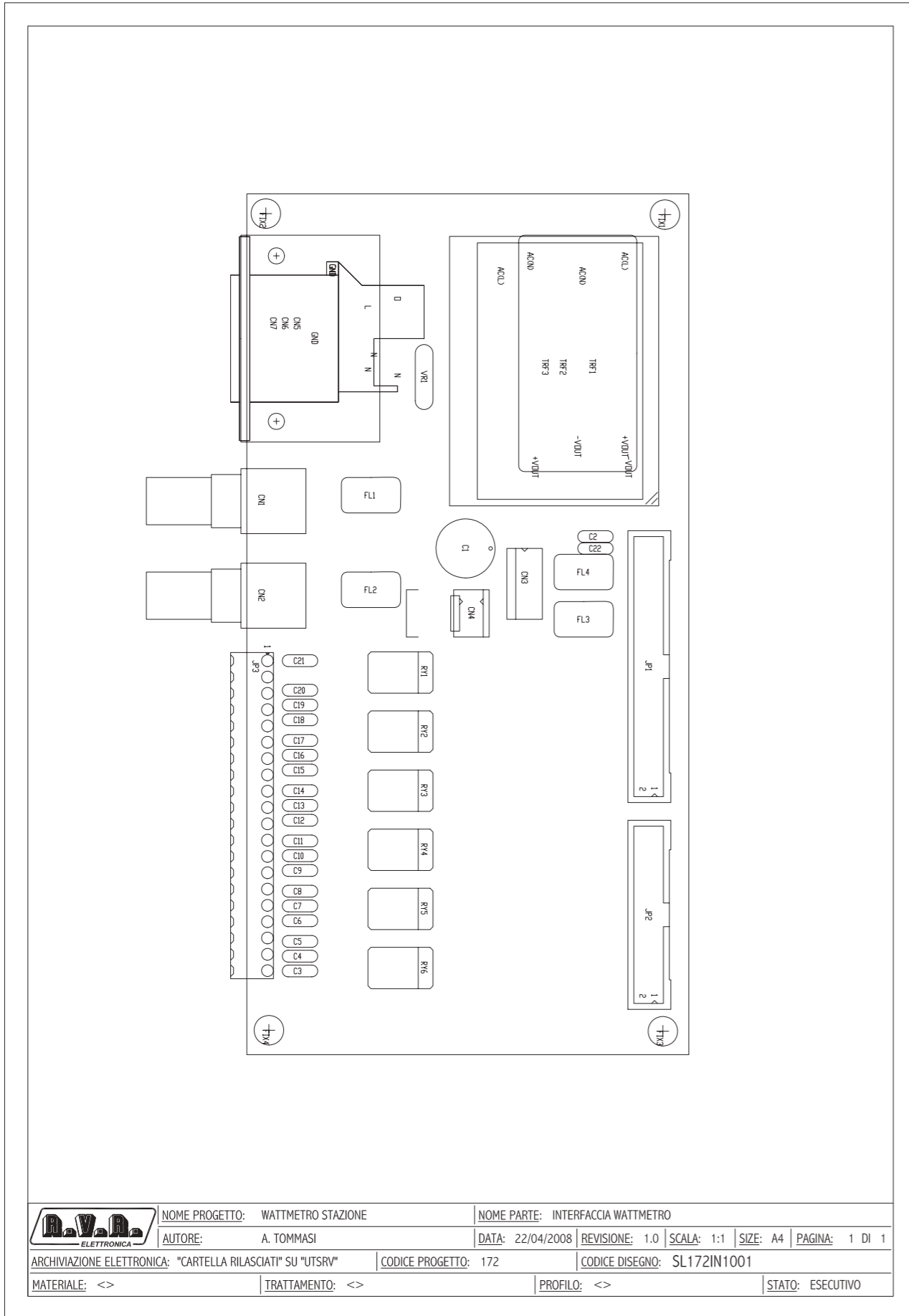

SL172IN1001

Scheda interfaccia Revised: Tuesday, February 19, 2008  
SL172IN1001 Revision: 1.0  
A. Tommasi  
Wattmetro di stazione  
RVR172

Item	Quantity	Reference	Part
1	2	CN1,CN2	BNC_IS90
2	1	CN3	CN06PS
3	1	CN4	CN02MR
4	1	CN5	VDEPF30PC
5	1	CN6	VDEKEA1PH
6	1	CN7	VDEKEA2PH
7	1	CS1	CSIN0168R2
8	1	C1	220uF/25V
9	2	C2,C22	0.1uF
10	19	C3,C4,C5,C6,C7,C8,C9,C10, C11,C12,C13,C14,C15,C16, C17,C18,C19,C20,C21	10nF
11	4	FIX1,FIX2,FIX3,FIX4	FIX35
12	4	FL1,FL2,FL3,FL4	DSS310-22nF
13	1	JP1	CN40PD
14	1	JP2	CN26PD
15	1	JP3	CTM209P8
16	6	RY1,RY2,RY3,RY4,RY5,RY6	RLYTQ2B
17	1	TRF1	TMLM05112
18	1	TRF2	CFM05S120
19	1	TRF3	ESCA5002
20	1	VR1	MOV250V20



PROTF172

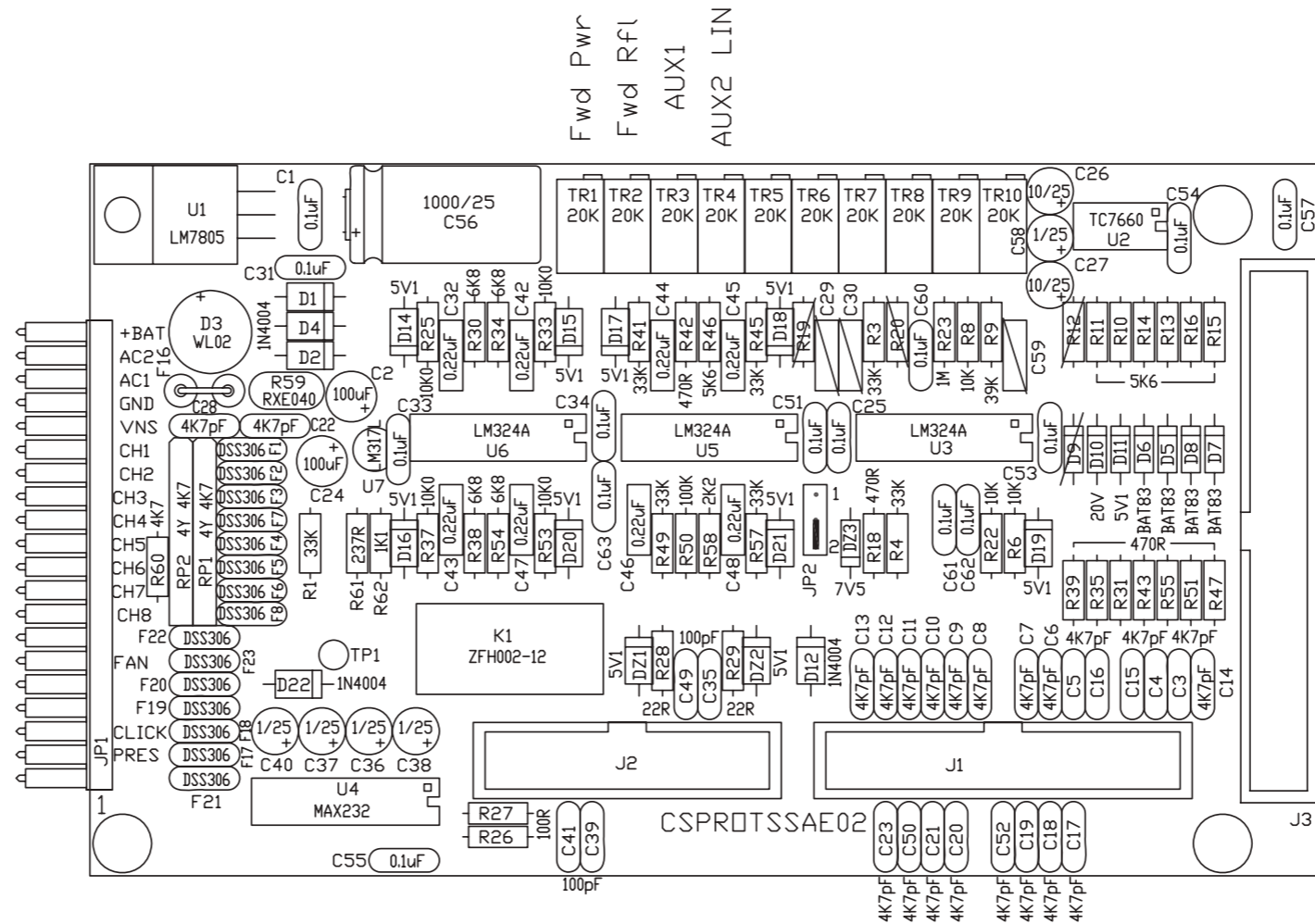

TITLE			PIANO DI MONTAGGIO PROTEZIONE MOSFET ANALOGICA		
DOCUMENT NUMBER		ANA_WATT_M. DWG		REV 1	
DATE:		26 marzo 2008			

PROTF172

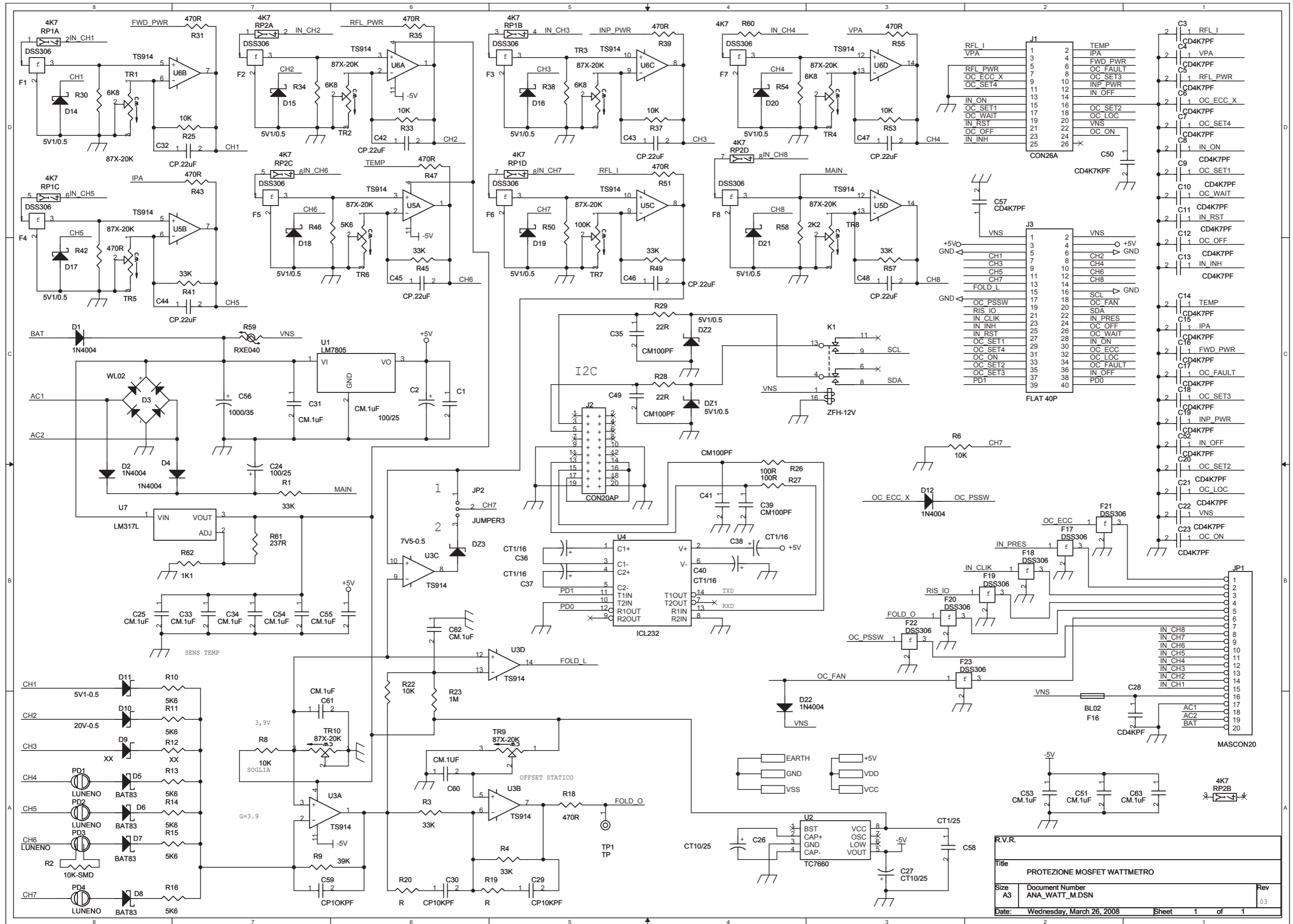

PROTF172

PROTEZIONE MOSFET WATTMETRO Revised: Wednesday, March 26, 2008  
 ANA\_WATT\_M.DSN Revision: ?  
 R.V.R.

Item	Quantity	Reference	Part
1	13	C1, C25, C31, C33, C34, C51, C53, C54, C55, C60, C61, C62, C63	CM.1uF
2	2	C2, C24	100/25
3	23	C3, C4, C5, C6, C7, C8, C9, C10, C11, C12, C13, C14, C15, C16, C17, C18, C19, C20, C21, C22, C23, C52, C57	CD4K7PF
4	2	C26, C27	CT10/25
5	1	C28	CD4KPF
6	2	C29, C30	CP10KPF
7	8	C32, C42, C43, C44, C45, C46, C47, C48	CP.22uF
8	4	C35, C39, C41, C49	CM100PF
9	4	C36, C37, C38, C40	CT1/16
10	1	C50	CD4K7KPF
11	1	C56	1000/35
12	1	C58	CT1/25
13	1	C59	CP10KPF
14	10	DZ1, DZ2, D14, D15, D16, D17, D18, D19, D20, D21	5V1/0.5
15	1	DZ3	7V5-0.5
16	5	D1, D2, D4, D12, D22	1N4004
17	1	D3	WL02
18	4	D5, D6, D7, D8	BAT83
19	2	D9, R12	XX
20	1	D10	20V-0.5
21	1	D11	5V1-0.5
22	15	F1, F2, F3, F4, F5, F6, F7, F8, F17, F18, F19, F20, F21, F22, F23	DSS306
23	1	F16	BL02
24	1	JP1	MASCON20
25	1	JP2	JUMPER3
26	1	J1	CON26A
27	1	J2	CON20AP
28	1	J3	FLAT 40P
29	1	K1	ZFH-12V
30	4	PD1, PD2, PD3, PD4	LUNENO
31	3	RP1, RP2, R60	4K7
32	7	R1, R3, R4, R41, R45, R49, R57	33K
33	1	R2	10K-SMD
34	7	R6, R8, R22, R25, R33, R37, R53	10K
35	1	R9	39K
36	7	R10, R11, R13, R14, R15, R16, R46	5K6
37	9	R18, R31, R35, R39, R42, R43, R47, R51, R55	470R
38	2	R19, R20	R
39	1	R23	1M
40	2	R26, R27	100R
41	2	R28, R29	22R
42	4	R30, R34, R38, R54	6K8
43	1	R50	100K
44	1	R58	2K2
45	1	R59	RXE040
46	1	R61	237R
47	1	R62	1K1
48	1	TP1	TP
49	10	TR1, TR2, TR3, TR4, TR5, TR6, TR7, TR8, TR9, TR10	87X-20K
50	1	U1	LM7805
51	1	U2	TC7660
52	3	U3, U5, U6	TS914
53	1	U4	ICL232
54	1	U7	LM317L

PROTF172

TITLE	PIANO DI MONTAGGIO CPU_MDS
DOCUMENT NUMBER	CPU_WATT_M_DWG
DATE	26 MARZO 2008
REV	

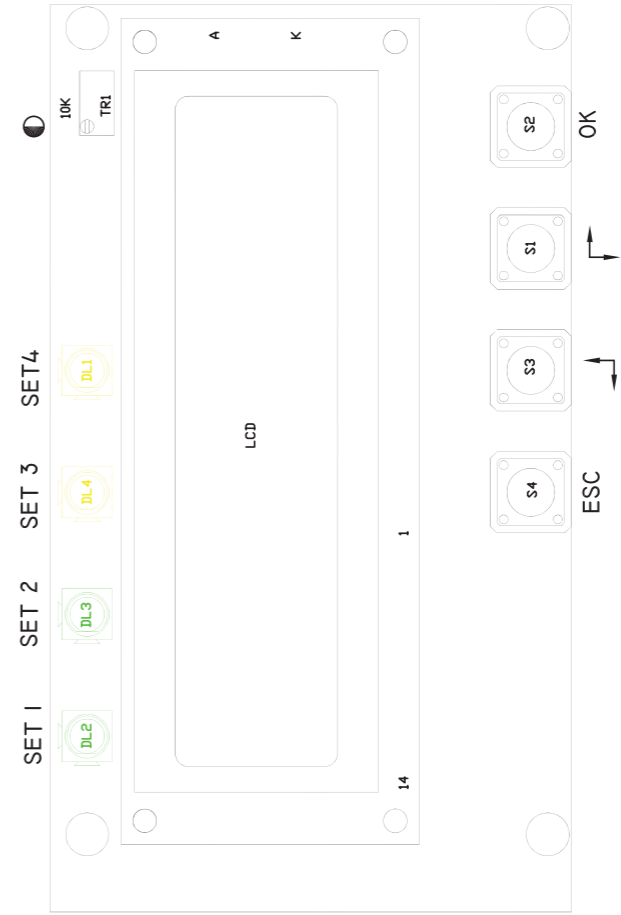
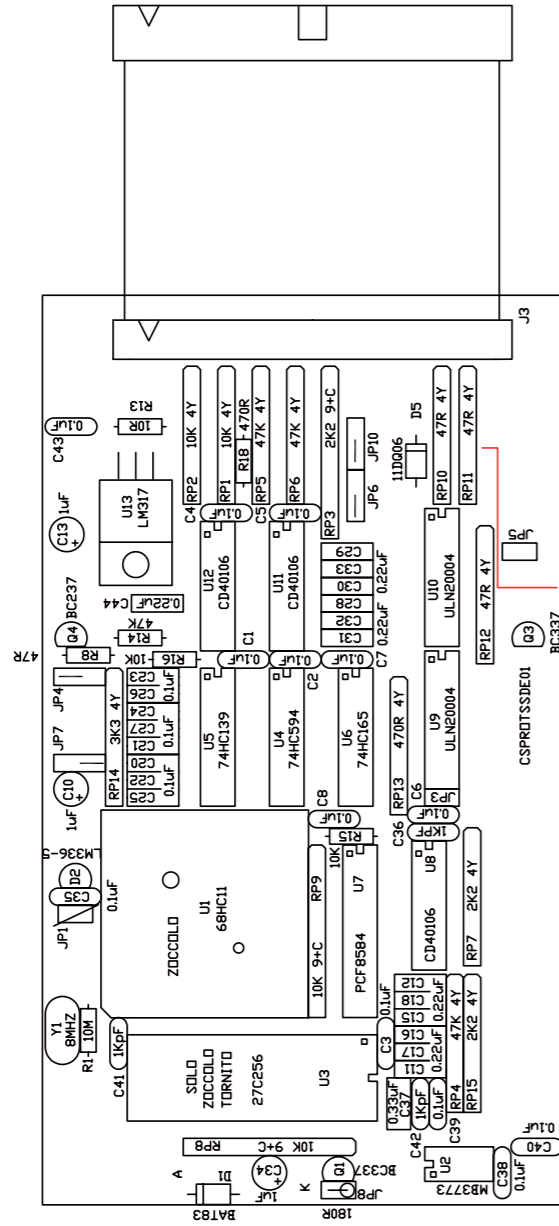

TITLE	PIANO DI MONTAGGIO CPU_MDS
DOCUMENT NUMBER	CPU_WATT_M_DWG
DATE	26 MARZO 2008
REV	

PROTF172

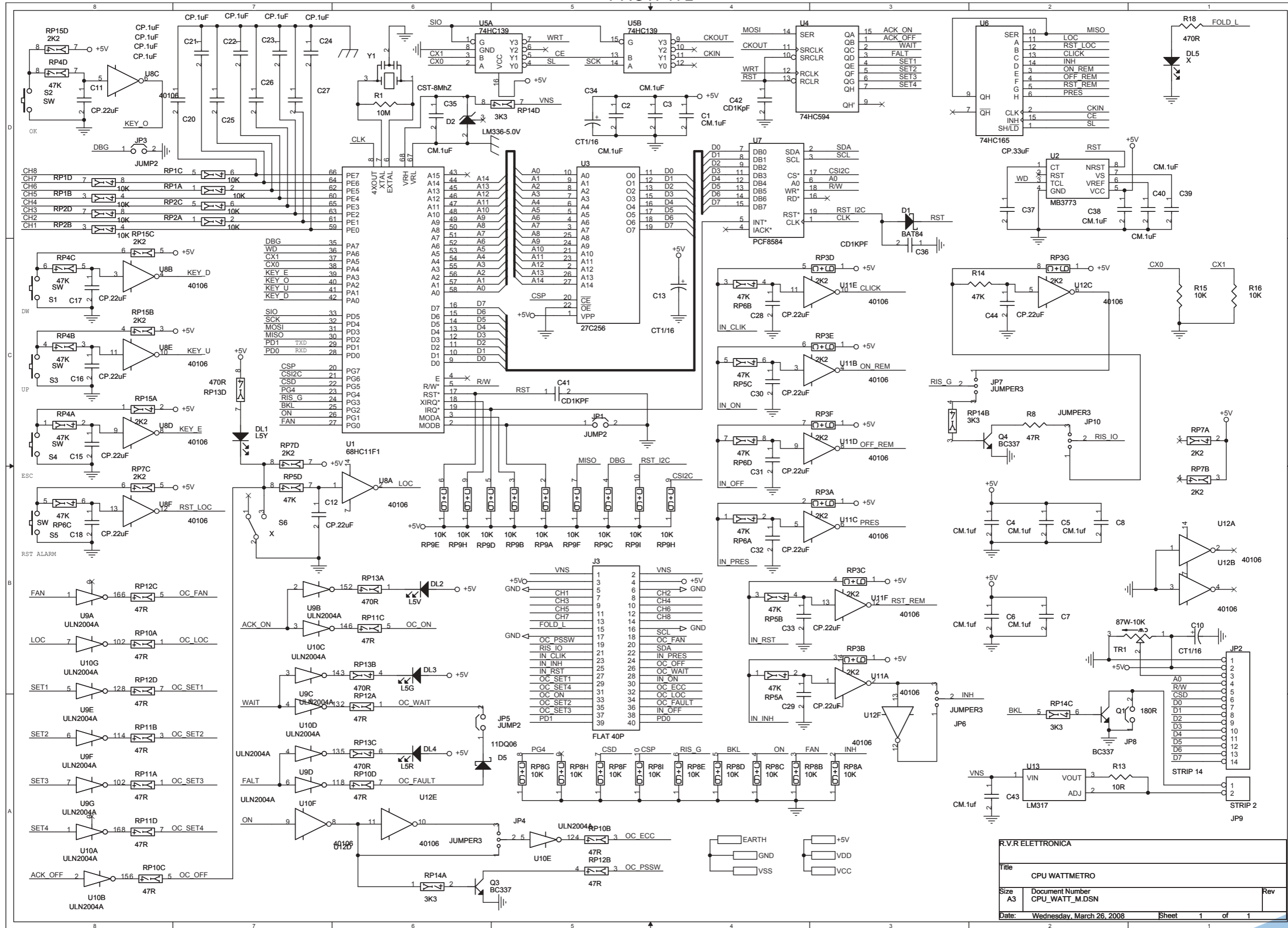

R.V.R. ELETTRONICA	
Title	CPU WATTMETRO
Size	A3
Document Number	CPU_WATT_M.DSN
Date:	Wednesday, March 26, 2008
Sheet	1 of 1

PROTF172

CPU WATTMETRO Revised: Wednesday, March 26, 2008  
 CPU\_WATT\_M.DSN Revision: ?  
 R.V.R ELETTRONICA

Item	Quantity	Reference	Part
1	13	C1, C2, C3, C4, C5, C6, C7, C8, C35, C38, C39, C40, C43	CM.1uf
2	3	C10, C13, C34	CT1/16
3	13	C11, C12, C15, C16, C17, C18, C28, C29, C30, C31, C32, C33, C44	CP.22uF
4	8	C20, C21, C22, C23, C24, C25, C26, C27	CP.1uF
5	3	C36, C41, C42	CD1KpF
6	1	C37	CP.33uF
7	1	DL1	L5Y
8	1	DL2	L5V
9	1	DL3	L5G
10	1	DL4	L5R
11	2	DL5, S6	X
12	1	D1	BAT84
13	1	D2	LM336-5.0V
14	1	D5	11DQ06
15	3	JP1, JP3, JP5	JUMP2
16	1	JP2	STRIP 14
17	4	JP4, JP6, JP7, JP10	JUMPER3
18	1	JP8	180R
19	1	JP9	STRIP 2
20	1	J3	FLAT 40P
21	3	Q1, Q3, Q4	BC337
22	6	RP1, RP2, RP8, RP9, R15, R16	10K
23	3	RP3, RP7, RP15	2K2
24	4	RP4, RP5, RP6, R14	47K
25	4	R8, RP10, RP11, RP12	47R
26	2	RP13, R18	470R
27	1	RP14	3K3
28	1	R1	10M
29	1	R13	10R
30	5	S1, S2, S3, S4, S5	SW
31	1	TR1	87W-10K
32	1	U1	68HC11F1
33	1	U2	MB3773
34	1	U3	27C256
35	1	U4	74HC594
36	1	U5	74HC139
37	1	U6	74HC165
38	1	U7	PCF8584
39	3	U8, U11, U12	40106
40	2	U9, U10	ULN2004A
41	1	U13	LM317
42	1	Y1	CST-8MhZ